

**TOWN OF HARVARD
PLANNING BOARD AGENDA
MONDAY, MAY 6, 2024 @ 7:00PM VIRTUAL MEETING via Zoom**

Pursuant to Chapter 2 of the Acts of 2023, An Act Making Appropriations for the Fiscal Year 2023 to Provide for Supplementing Certain Existing Appropriations and for Certain Other Activities and Projects, and signed into law on March 29, 2023, this meeting will be conducted via remote participation. Interested individuals can listen in and participate by phone and/or online by following the link and phone number below.

THVolGovt Pro is inviting you to a scheduled Zoom meeting.

Topic: Planning Board

Time: May 6, 2024 07:00 PM Eastern Time (US and Canada)

Join Zoom Meeting

<https://us02web.zoom.us/j/81619756207?pwd=Mk44cnlwZkprSzNRR0lwMjVPbERNdz09>

Meeting ID: 816 1975 6207

Passcode: 335767

One tap mobile

+19294362866,,81619756207# US (New York)

+13017158592,,81619756207# US (Washington DC)

Dial by your location

• +1 929 436 2866 US (New York)

• +1 301 715 8592 US (Washington DC)

• +1 305 224 1968 US

Meeting ID: 816 1975 6207

Find your local number: <https://us02web.zoom.us/j/81619756207?pwd=Mk44cnlwZkprSzNRR0lwMjVPbERNdz09>

Public Comment

Old Business: a) Proposed Town Center Overlay District and Town Center Action Plan
b) 2016 Master Plan progress report
c) 2026 Master Planning steering committee & funding request
d) Discussion of Ayer Road Vision Plan & Form Based Code

New Business: Discussion of potential Form-based Code in C-District with UTILE.

Public Hearings:

7:15pm Public Hearing requested by Scott Patterson for approval of a Site Plan Review at 256 Ayer Road with an amendment to an existing Special Permit or other relief as appropriate under M.G.L Chapter 40A, and the "Code of the Town of Harvard" as amended, the Protective Bylaw Chapters 125-23(B)(2) and §125-38 to request a modification of the existing approvals, (Special permit with site plan review), to construct a stand-alone structure within the originally proposed reconstructed garage.

7:45pm Continuation of a Public Hearing requested by Atty. Pamela J. Brown for David Rossi of Bespoke Landscaping 288 Ayer Road, Harvard seeking approval of a Site Plan Review with a Special Permit or other relief as appropriate under M.G.L Chapter 40A, and the "Code of the Town of Harvard" as amended, the Protective Bylaw Chapters 125-23 B(1) (Medium Scale Commercial Uses) and §125-13T Landscaping business & §125-13Y Warehousing as well as §125-38 Site plan approval with Special permit - Permitted uses in C Districts.

Standard Business: a) Review Metrics

The listing of matters are those reasonably anticipated by the Chair which may be discussed at the meeting. Not all items listed may in fact be discussed and other items not listed may be brought up for discussion to the extent permitted by law, also.

- b) Board Member Reports
 - Representatives & Liaisons Update
 - Community Matters
- c) Master Planning for 2026
- d) Approve Minutes: April 22, 2024
- e) Approve Invoice:

**NEXT SCHEDULED MEETINGS:
MONDAY, MAY 20, 2024**

AS/bny

The listing of matters are those reasonably anticipated by the Chair which may be discussed at the meeting. Not all items listed may in fact be discussed and other items not listed may be brought up for discussion to the extent permitted by law, also.

Special Permit Modification

***256 Ayer Road
Harvard, MA***

March 2024

**Submitted to:
*Harvard Planning Board
13 Ayer Street
Harvard, MA 01451***

**Submitted by:
*256 Ayer Road, LLC
11 Spring Street
Lunenburg, MA 01462***

**Prepared by:
*Goldsmith, Prest & Ringwall, Inc.
39 Main Street, Suite 301
Ayer, MA 01432***

**Project No:
*181090***



Table of Contents

Application to the Harvard Planning Board

Cover Letter

Appendix

Assessor's Map

Certified List of Abutters within 300'

Approved Special Permit Decision - June 15, 2020.
11x17 of Approved Plan

Approved Modification to a Special Permit Decision - April 25, 2022.
11x17 of Approved Plan

Attachments

Special Permit - Large Scale Commercial Uses -Site Plan & Construction
Details - 256 Ayer Road Harvard, MA
Prepared by Goldsmith, Prest & Ringwall, Inc. Dated March, 2024

36' x 16' x 70' Building - Architectural Sketch
Prepared by Morton Buildings, Inc. Dated February, 2024

Fee Check

APPLICATION TO THE HARVARD PLANNING BOARD

Applicants should review the Harvard Protective (Zoning) Bylaw, Chapter 125 of the Code of the Town of Harvard, the Planning Board's Rules and Regulations, Chapter 133 of the Code of the Town of Harvard and the Requirements regarding Driveway Inspections (Chapter 125 of the Protective Bylaw). Copies of the Bylaw may be purchased from the Town Clerk and copies of the Rules and Regulations may be purchased from the Land Use Office. Information is also available online at www.harvard.ma.us. The Rules and Regulations specify the documents that are required as a part of the application. The Application, with certified abutters list and filing fee, must be filed with the Town Clerk.

Name of Applicant: Scott Patterson

Address: 11 Spring Street, Lunenburg, MA Phone: 978-868-8212 Email: scott.itbb@gmail.com

Applicant is (check one): Owner Agent Prospective Buyer

Location of Property: 256 Ayer Road Harvard, MA Zoning District: Commercial (C)

Harvard Assessors' Map 04 Parcel 41

Registry of Deeds: Book Number 59556 Page Number 235

Owner's Name: 256 Ayer Road, LLC Email: scott.itbb@gmail.com

Owner's Address: 11 Spring Street, Lunenburg, MA 01462 Owner's Phone: 978-868-8212

Seventeen (17) copies of the application must be submitted to the Town Clerk. This application is for:

- Special Permits* \$500/required permit
- Driveway Site Plan \$180
- Inspections of Driveways \$300
- Approval of Covenant \$100
- Wireless Communication Tower \$2500
- Consultant Review Fee** \$1000
- Site Plan Review with a Special Permit \$180
- Site Plan Review without a Special Permit \$500
- Modification/Extension 1/2 of original application fee

Specific bylaw section(s) you are applying under 125-23(B)(2) - Permitted uses in C Districts

* Unless otherwise specified

** Required with all Special Permit Applications. This is a deposit to cover costs of Planning Board consultants and additional amounts may be required depending on the complexity of the Application. All unused monies will be returned. Please submit "Request for New Vendor" form with application. (Available on line at www.harvard.ma.us under Forms & Documents)

All applications associated with a Wireless Communication Tower requires proof of compliance with § 125-27H(2)

All filing fees are cumulative. All Special Permits and uses subject to Site Plan Approval require Driveway Inspections and written approval by the Planning Board, or its agent, prior to issuance of an occupancy permit or use of the premises (§ 125-31 C) All Shared (common) Driveways require an approved covenant running with the land in accordance with § 125-31 B (4) (b). The applicant will be required to pay a local newspaper of general circulation for the current cost of advertising the hearing. The applicant will be billed directly from the newspaper for the cost of the advertised hearing or all advertising must be paid for in full prior to submittal to the newspaper. The undersigned hereby requests a hearing before the Planning Board with reference to this application.

Signed: 



March 26, 2024

Harvard Planning Board
Hildreth House, Annex of Town Hall
15 Elm Street, Harvard, MA 01451

RE: Request for Site Plan and Special Permit Modification
'The Barn' - 256 Ayer Road, Harvard, MA

Dear Board Members:

"The Barn" located at 256 Ayer Road originally obtained a Special Permit for a Large-Scale Commercial Use & associated Site Plan approval from in June of 2020 (recorded in book 62962 page 61). That application and approval detailed the conversion of the existing auto service garage into an Indoor Recreational Facility (batting cages). Within said application, along with the conversion of the service bay(s) areas to batting cages, the existing dwelling was to be renovated, a portion of the existing auto garage structure completely demolished and the reconstruction of the southern end of the structure to a detached garage. A public water supply well and new septic system were also installed at the time of the original approval to support the proposed use(s).

'The Barn' provides batting cages and a practice/workout space supporting a private preparatory baseball club, North East Baseball Club, aka NEB, fielding travel teams ranging from under 12 to under 18. The final fit up of the former service area space during initial construction resulted in the largest, northernmost portion of the footprint having batting cages installed. The narrower portion to the south was dedicated to a weight / workout area along with bathrooms being constructed. Once these player workout areas were established, the limits of the existing space relative to the limits of the existing space were realized. Specifically, the amount of various traditional and plyometric equipment within the confines of the workout area actually made the most common routine the unstacking and restacking of equipment. In an attempt to alleviate the cramped conditions, a modification of the Special Permit & Site Plan was requested in 2022. Said request outlined the swapping of the impervious surface created by the reconstructed detached garage structure for an addition to the large batting cage footprint, approximately squaring off the structure. The modification request was approved with a decision being issued on April 25, 2022 (recorded in book 70156 page 142).

Since the issuance of the modified approvals, the cost and what would be required efforts associated with expanding the batting cage structure building have caused the applicant to shift once again to request a modification of the existing approvals to construct a standalone structure within the originally proposed reconstructed garage location. The proposed structure will allow the relocation of the workout activities to the new structure while allowing the current

Goldsmith, Prest & Ringwall, Inc.

workout area to be used for administrative purposes, such as a reception area and a waiting area for parents of the players using the facilities.

The intent of the proposed detached structure would be the same as the previously approved attached structure, where a larger area could be dedicated to the workout facility, freeing up space in the current building area, and providing more room to operate. There is no proposed expansion to the use or capacity of the business associated with this request. This request for modification is similar to the previous in that it provides an expanded area for the workout portion of the facility, with the current request for modification while not having to contend with complications associated with the expansion of an older existing structure and the reconfiguration of existing utility services.

As shown on the attached plan, the detached structure is proposed approximately 27-ft to the south of the existing facility and would have a gravel parking area to provide three 9x19 parking spaces for direct access. The proposed structure removes 1,956 square feet of impervious area approved under the existing modified approvals and replaces it with 2,520 sf of the standalone structure. To mitigate stormwater runoff from the additional 564± sf of the proposed structure a 2'x2' crushed stone drip edge is proposed along the southerly side of the new structure to collect roof runoff. Stormwater calculations are shown on the attached plan show the proposed volume of the crushed stone drip edge (112± cubic feet) will hold and infiltrate just under 2.5 times the volume of natural infiltration lost due to the additional impervious area (47± cf). During larger storm events and once the available volume of is full, the drip edge area will overflow allowing runoff to continue to the south within the existing runoff paths of the current site.

Based on standard condition IX of the April 25, 2022, Harvard Planning Board Decision, we respectfully submit this letter, associated documents, and plan to the Board for the proposed Modification to the Special Permit & Site Plan. As you are aware the Board has issued a Special Permit for the use of indoor commercial recreation. The applicant desires to maintain the use permitted within a facility with a little more space to operate and provide stormwater mitigation measures for impervious area increase.

On behalf of the applicant, Scott Patterson of 256 Ayer Road, LLC, GPR, Inc. asks that you approve this request for a Modification to the previously approved Special Permit & Site Plan.

Thank you,
Goldsmith, Prest & Ringwall, Inc.



Nicholas M. Pauling, PE

Attachments - Site Photos

Copy to: Scott Patterson, 256 Ayer Road, LLC
GPR File 181090

Site Photos



Photo 1: Facing southeast from northerly most driveway. "The Barn" (left), garage (center) & dwelling (right).



Photo 2: Facing south from northerly most driveway. "The Barn" (left), garage (center) & dwelling (right).



Photo 3: Facing southeast from inner-driveway connection, looking at garage.



Photo 4: Facing east from southerly most driveway. Dwelling (left), "The Barn" (center), & garage (right)

APPENDIX



256 Ayer Road

Town of Harvard, MA

1 inch = 500 Feet



www.cai-tech.com

March 14, 2024

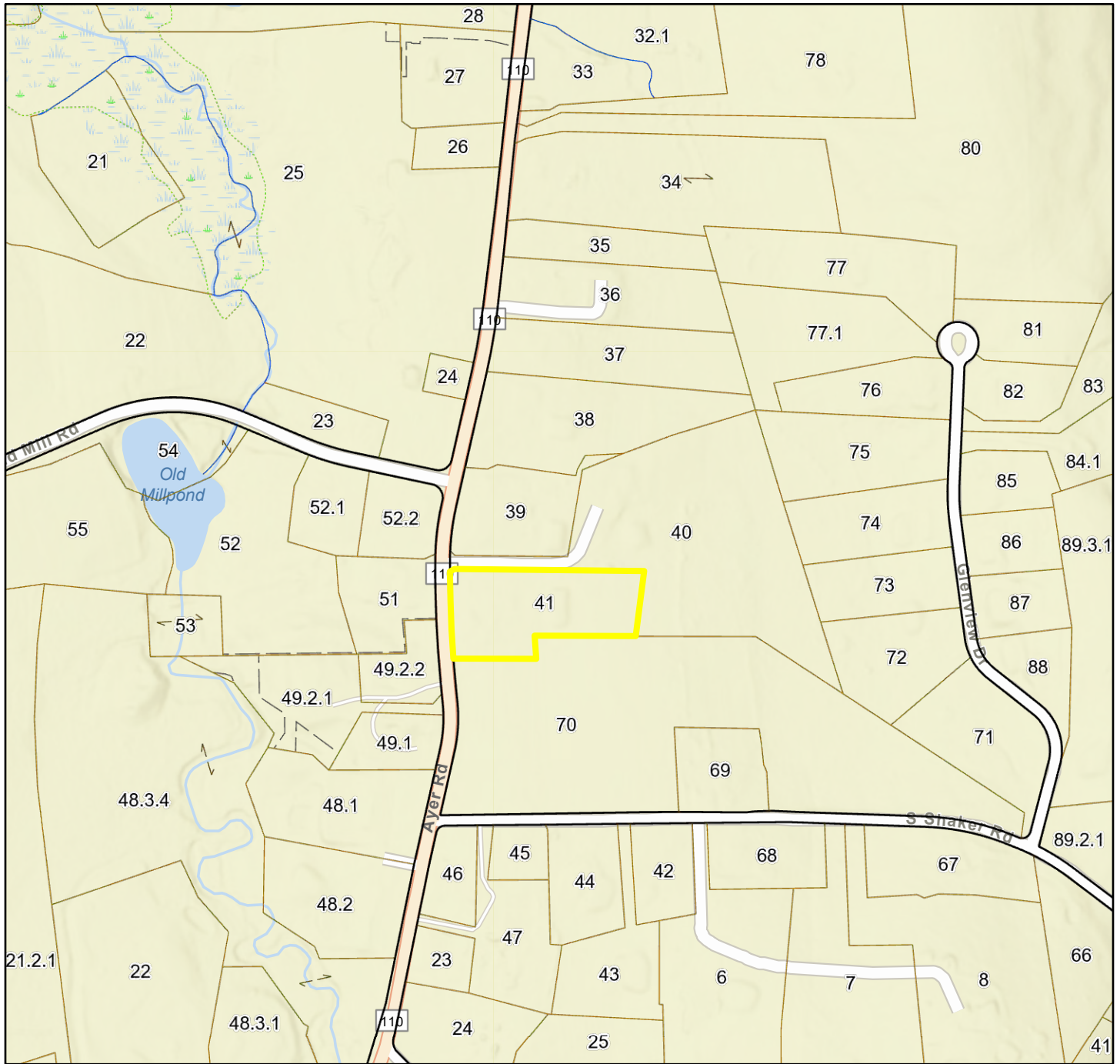

	PWater		Right of Way		WaterLines
	Property Line		Property Hook		Wet Areas
	Public Road		Wetland		

Data shown on this map is provided for planning and informational purposes only. The municipality and CAI Technologies are not responsible for any use for other purposes or misuse or misrepresentation of this map.



Abutters List Report
Town of Harvard, MA

Date: March 18, 2024

Parcel Number: 004-041-000-000

Property Address: 256 Ayer Rd

Abutters To: 300ft

The above Certified Abutters List is a true copy of the records in the Town of Harvard Assessor's office for the last known names and addresses of owners of land located within the above stated range of the subject property.

Signed: _____

Date: _____

3/18/24

Carol Dearborn
Assistant Assessor
(978) 456-4100 x315

FINANCE DEPARTMENT - ACCOUNTANT, ASSESSORS, TREASURER/COLLECTOR

13 Ayer Road, Harvard, Massachusetts 01451-1458

www.harvard-ma.gov



256 AYER RD

Town of Harvard, MA

1 inch = 556 Feet



www.cai-tech.com

March 18, 2024

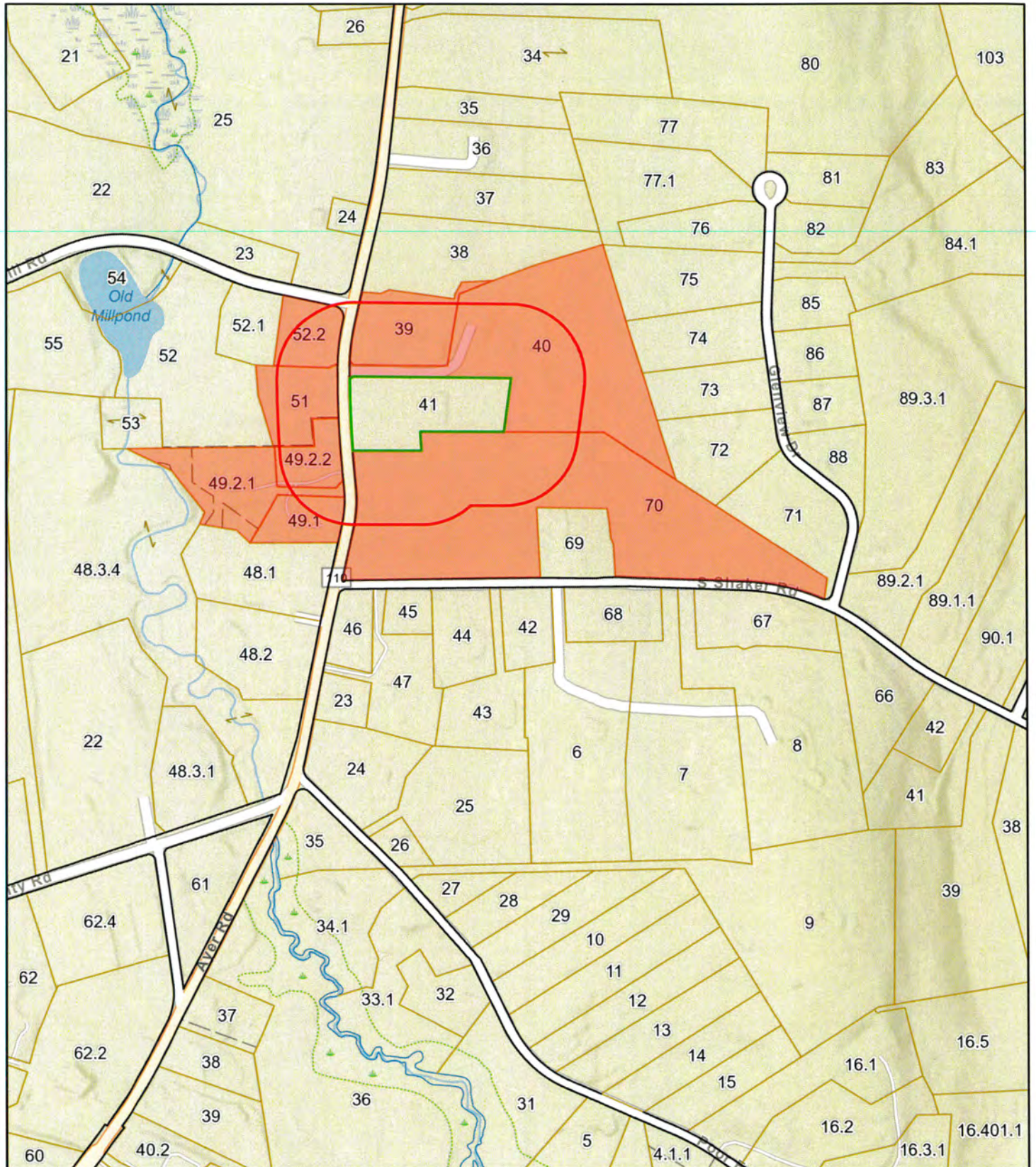

Data shown on this map is provided for planning and informational purposes only. The municipality and CAI Technologies are not responsible for any use for other purposes or misuse or misrepresentation of this map.



300 feet Abutters List Report

Harvard, MA
March 18, 2024

Subject Property:

Parcel Number: 004-041-000-000
CAMA Number: 004-041-000-000
Property Address: 256 AYER RD

Mailing Address: 256 AYER ROAD, LLC
11 SPRING ST
LUNENBURG, MA 01462

Abutters:

Parcel Number: 004-039-000-000
CAMA Number: 004-039-000-000
Property Address: 264 AYER RD

Mailing Address: THREE SEASONS TREESCAPE, LLC
106 OLD MILL RD
HARVARD, MA 01451

Parcel Number: 004-040-000-000
CAMA Number: 004-040-000-000
Property Address: 262 AYER RD

Mailing Address: DKMP REALTY, LLC
262 AYER RD
HARVARD, MA 01451

Parcel Number: 004-049-001-000
CAMA Number: 004-049-001-000
Property Address: 249 AYER RD

Mailing Address: BLANCHARD HOUSE OFFICES LLC
PO BOX 1560
MANCHESTER, MA 01944

Parcel Number: 004-049-002-001
CAMA Number: 004-049-002-001
Property Address: 253 AYER RD

Mailing Address: FOXGLOVE HOUSING ASSOC LTD
PO BOX 250
IPSWICH, NH 03071

Parcel Number: 004-049-002-002
CAMA Number: 004-049-002-002
Property Address: 257 AYER RD

Mailing Address: OFFICE AT 257 AYER RD LLC
79 CANTERBURY HILL RD
ACTON, MA 01720

Parcel Number: 004-051-000-000
CAMA Number: 004-051-000-000
Property Address: 259 AYER RD

Mailing Address: 259 AYER ROAD LLC
871 MASSACHUSETTS AVE
BOXBOROUGH, MA 01719

Parcel Number: 004-052-002-000
CAMA Number: 004-052-002-000
Property Address: AYER RD

Mailing Address: REM REALTY TRUST
23 MIDSTATE DR., SUITE 116
AUBURN, MA 01501

Parcel Number: 005-070-000-000
CAMA Number: 005-070-000-000
Property Address: AYER RD

Mailing Address: MICHAEL MORTON, ABBE ALPERT, GINA
ASHE, et al, TRU
P.O. BOX 31
HARVARD, MA 01451



www.cai-tech.com

3/18/2024

Data shown on this report is provided for planning and informational purposes only. The municipality and CAI Technologies are not responsible for any use for other purposes or misuse or misrepresentation of this report.

Page 1 of 1

259 AYER ROAD LLC
871 MASSACHUSETTS AVE
BOXBOROUGH, MA 01719

BLANCHARD HOUSE OFFICES L
PO BOX 1560
MANCHESTER, MA 01944

DKMP REALTY, LLC
262 AYER RD
HARVARD, MA 01451

FOXGLOVE HOUSING ASSOC LT
PO BOX 250
IPSWICH, NH 03071

MICHAEL MORTON, ABBE ALPE
P.O. BOX 31
HARVARD, MA 01451

OFFICE AT 257 AYER RD LLC
79 CANTERBURY HILL RD
ACTON, MA 01720

REM REALTY TRUST
23 MIDSTATE DR., SUITE 116
AUBURN, MA 01501

THREE SEASONS TREESCAPE,
106 OLD MILL RD
HARVARD, MA 01451

RECEIVED
HARVARD TOWN CLERK

2020 JUL -6 PM 4:14

OFFICE OF THE
PLANNING BOARD

13 AYER ROAD HARVARD, MA 01451

978-456-4100

www.harvard.ma.us



To: Marlene Kenney, Town Clerk
Harvard Town Hall
13 Ayer Road
Harvard, MA 01451

JUNE 15, 2020

HARVARD PLANNING BOARD

**NOTICE OF DECISION ON APPLICATION OF SCOTT
PATTERSON FOR A SPECIAL PERMIT AND SITE PLAN
APPROVAL FOR THE ESTABLISHMENT OF AN INDOOR
ATHLETIC FACILITY AT**

256 AYER ROAD

HARVARD, MA 01451

ASSESSORS MAP 4 – PARCEL 41

WORCESTER REGISTRY OF DEEDS

BOOK 59556 PAGE 235

PROCEDURAL HISTORY

- I. Application for the establishment of an indoor athletic facility as per §125-14, Large-scale commercial uses, of The Protective Bylaw, for a Special Permit and site plan review pursuant to Protective Bylaw, for the property located at 256 Ayer Road was made by the above referenced applicant.
- II. The following plans and documents were submitted in support of the application:
 - A. An application for a Special Permit and site plan review with a Special Permit for an indoor athletic facility pursuant to §125-14 of the Town of Harvard Protective Bylaw was received by the Harvard Town Clerk on April 28, 2020, including a cover letter from Nicholas Pauling, P.E. of Goldsmith, Prest, & Ringwall, Inc. (GPR) dated April 27, 2020 and the following:
 1. Corresponding fees paid via check #234 for \$680.00 dated April 16, 2020
 2. A document entitled "Special Permit Application, 256 Ayer Road, Harvard, MA", which also included:
 - a. Application form referenced above

Town Clerk
True Copy Attest

b. Cover letter referenced above

c. Letter of agent authorization dated April 16, 2020

d. Certified abutters list report dated April 16, 2020

B. A plan set dated April 2020 entitled "Special Permit, Large Scale Commercial Uses, Site Plan & Construction Details, 256 Ayer Road, Harvard, MA" prepared for applicant Scott Patterson, 11 Spring Street, Lunenburg, MA 01462, by Goldsmith, Prest, & Ringwall, Inc., 39 Main Street, Suite 301, Ayer, MA 01432, JOB 181090, containing one (1) sheet.

C. A revised plan set dated June 9, 2020 entitled "Special Permit, Large Scale Commercial Uses, Site Plan & Construction Details, 256 Ayer Road, Harvard, MA" prepared for applicant Scott Patterson, 11 Spring Street, Lunenburg, MA 01462, by Goldsmith, Prest, & Ringwall, Inc., 39 Main Street, Suite 301, Ayer, MA 01432, JOB 181090, containing one (1) sheet.

D. An undated graphic rendering entitled "256 Ayer Road / Potential Residential Garage Representation" showing an elevation drawing of the proposed design of the garage rehabilitation.

III. The following additional documents were provided to the Planning Board in regard to the application:

A. E-mail communication from the Harvard DPW Director, in regard to Special Permit & Site Plan Review, 256 Ayer Road, dated May 12, 2020.

B. E-mail communication from Andrew Perry, Lieutenant/Fire Prevention, Harvard Fire Department, in regard to 256 Ayer Road, dated May 12, 2020.

IV. Legal Notices: Advertised and Letters to Abutters

A. An Affidavit of Mailing to Abutters dated May 12, 2020 was endorsed by the Town Clerk on [the same date].

B. A Legal Notice advertising the virtual public hearing to be held on June 1, 2020 on the Special Permit for the operation of an indoor athletic facility appeared in "The Harvard Press" on May 15, 2020 and May 22, 2020.

V. A public hearing, after proper notice was given, was opened on June 1, 2020 and closed on June 15, 2020.

VI. Public Input

At public hearing sessions held on June 1, 2020 and June 15, 2020, the representatives of the applicant attended including Scott Patterson and Nicholas Pauling, PE.

Members of the public attending public hearings: None.

BACKGROUND AND FINDINGS

The Harvard Planning Board reviewed the application, the plan sets, and all other materials and information submitted prior to the close of the public hearing. The Board received and gave due consideration to the testimony given at the public hearing. The following is a compilation of the comments provided by the Director in review of the application and plans.

I. General

A. The subject property is a 3.63 ± acre parcel (3.54 acres on GIS) within a Commercial (C) zoning district and the land use is commercial and residential with 2 existing buildings (commercial at 6086 s.f. and residential at 1966 s.f.).

B. The following zoning tables assesses conformance with zoning dimensional criteria:

Requirement	Required	Provided	Conformance
Minimum Lot Area	1.50 acres	3.63 acres	Y
Floor Area Ratio (FAR)	10% or 8000 s.f.	5%	Y
Lot Frontage	180'	282' est.	Y
Lot Width	200'	290' est.	Y
Minimum Side Yard	20'	48' est.	Y
Minimum Rear Yard	20'	420' est.	Y
Minimum Front Yard	20'	78' est.	Y
Maximum Height	35'/3 stories	Undetermined	No Data
Required Parking	No Specification	10 dedicated	NA
Loading Area	Required	No Data	No Data

II. Special Permit Criteria

A. Advice from Planning Board or other Town Boards

Fire Department – A “No comments” communication was received via email
 DPW – Comment from DPW Director forwarded to applicant team received via email

B. Special Permit Authorization

1. Will not result in substantial increase of volume or rate of surface water runoff to neighboring properties and streets, and will not result in substantial danger of pollution or contamination of the groundwater supply, a groundwater absorption area, a well, pond, stream, watercourse, W District, or inland wetland. Any and all surface water runoff resulting from development shall be retained within the lot in which it originates or shall be discharged into existing identifiable watercourses without material impact on abutting properties.

a. While no stormwater analysis was conducted, it is anticipated that there will be minor, if any, changes to stormwater as a result of the proposed project.

b. Pollution is not anticipated to be an issue.

2. Will, if the use is not agricultural or residential, result in no substantial increase in traffic, compared to refusal of the permit, on any residential street where the premises have access; and

Traffic generation not calculated or provided by applicant but it was speculated that there would be a minor increase, if any. The Director had recommended peer review if there was further concern by the Board. The Board did not indicate any concern.

3. Will be in harmony with the general purpose and intent of the Bylaw, including each purpose stated in § 125-1, Purpose, which is pertinent to the particular application.

- a. To conserve health;

Not deemed applicable.

- b. To secure safety from fire, wind, flood, and traffic;

May create minor traffic issues based on anticipated increased trip generation but no means to assess other than peer review.

- c. To preserve and increase the value of land and buildings;

The proposed use is not expected to be very different than current uses and if the buildings and site are improved over the current condition of the buildings and site, this is likely to slightly improve property values.

- d. To protect the community from the detrimental effects of unsuitable development;

While the proposed use is not in precise alignment with the goals for developing the Ayer Road corridor, it is a reasonable interim use and this is NOT unsuitable.

- e. To preserve and increase the amenities of the Town;

This proposal does not impact amenities.

- f. To prevent overcrowding of the land;

This is not applicable.

- g. To provide for compatibility with individual water supply and sewage disposal systems and their renewal, and with public systems which may become available;

This determination must come from the Board of Health.

- h. To facilitate future reuse and redevelopment of property;

The use and proposed improvement of the property does not impact future use.

- i. To provide for safe, rapid traffic flow to, from, and along the streets;

It is undetermined whether trip generation will increase and thus impact traffic flow and safety along Ayer Road.

- j. To avoid confusing and distracting signs in areas along the streets;

It is unknown what the design of the signs will be as no sign package was submitted. Director had recommended requesting a sign package from applicant should the Planning Board have wished to review more closely. The Board did not request additional information from the applicant.

- k. To avoid unsuitable traffic on residential streets;

This is not applicable.

- l. To preserve the streets of the Town as firebreaks;

This is not applicable.

- m. To protect persons and property against the hazards of inundation and pollution;

Inundation is assumed to be water and this is not expected to be a factor.

- n. To prevent pollution or contamination of, to conserve, and to protect watercourses, and their adjoining lands, groundwater absorption areas, and the groundwater table on which the inhabitants depend for their water supply;

Same recommendation as m. above.

- o. To preserve storage areas for seasonal or periodic high waters;

This does not appear to be applicable.

- p. To protect ponds from accelerated and excessive plant growth and premature decay into swamps;

This is not applicable.

- q. To conserve natural conditions and open spaces;

This is not applicable as there are no natural features impacted by the proposal.

- r. To separate and otherwise isolate potentially conflicting property uses.

This is not applicable.

The applicant shall show satisfactorily that the use will comply with the Bylaw including in particular § 125-20. If a special permit is authorized, the authorizing Board shall impose as a part of such permit conditions, safeguards, and limitations of time and use, in addition to any specifically provided in the Bylaw, as may be appropriate for protection of the neighborhood, the community, and the natural environment, including the groundwater supply, a groundwater absorption area, or other wetland resource.

C. Section 125-20 Use Criteria

1. No use is permitted which is injurious, offensive, or otherwise detrimental to the neighborhood, the community, or the natural environment, including the groundwater supply, a groundwater absorption area, or other wetland resources, because of:

a. Concussion, vibration, noise, or other mechanical disturbance;

Not anticipated.

b. Smoke, dust, odor, fumes, or other air pollution;

Not anticipated.

c. Glare, fluctuating light, or electrical interference;

It is not anticipated that light, glare, or electrical interference will be generated.

d. Danger of fire, explosion, radioactivity, or other danger;

Not anticipated.

e. Wastes or refuse (except at the Town Transfer Station);

There is a question of where waste staging will take place and what facilities will be used for the holding of wastes. The Director recommended that the Applicant should specifically note on site plan where waste receptacle(s) will be placed and what screening will be used. Additionally, what times of the day will waste be hauled away. The applicant responded that no commercial waste receptacle would be utilized on the property and there was no further discussion of this criterion.

f. Likelihood of substantial increase in volume or rate of surface water runoff to neighboring properties and streets, or substantial danger of pollution or contamination of the groundwater supply, a groundwater absorption area, or a well, pond, stream, watercourse, W District, or inland wetland;

Not anticipated.

g. Other characteristics.

None anticipated.

2. Development shall provide water supply and sewage disposal approved by the Board of Health.

Defer to comments to be provided by the Board of Health.

III. Site Plan Review Criteria

The following is an assessment of how the application meets the requirements of §125-38, Site Plans:

A. Content

1. Existing and proposed lot boundaries and buildings and other structures (including signs) within the lot or side setback area abutting the lot, including elevation views as well as plan views to show conformance to the Bylaw; and

Site plan does not technically show the full extents of the property, but a smaller scale full extent has been provided as an inset. Service bay garage (Sections 1 and 2), garage (Section 4), and existing residence are shown on plan. Elevation view concept submitted by the applicant.

2. Parking, loading, maneuvering, storage and service areas or uses, walkways, driveways, lighting, green areas and visual screening; and

The applicant had proposed fourteen (14) dedicated parking spaces for the business but eight (8) of these are tandem spaces and there is one (1) handicapped space that is part of the five (5) paved spaces in the front of the building. The other eight spaces are gravel. No internal walkways were proposed and no sidewalks on Ayer Road were proposed. The latter is challenging for reuse of buildings rather than redevelopment so the Board was recommended to take each on a case by case basis related to this provision although the better option would be to consider linkages to the proposed multi-use path as part of the road reconstruction project. Driveways include a pair of paved entrances with the northern wider entrance apparently intended to serve as a two-way access to the business while the narrower southern entrance is primarily for the residence, although they are connected and the Board was recommended to consider asking applicant how this would function. Fire and DPW had no comments other than DPW noting that a driveway connection permit would be required. There are no existing or proposed walkways and green areas include grass for most of the site and trees along the north property line, some of which show as being on the adjacent lot.

3. Provisions for water supply and reservoirs, surface water drainage, and treatment and disposal of sewage and any other wastes;

There appears to be a well serving the residence but no water supply is shown for the commercial buildings. There appears to be two septic tanks—one serving the residence and another serving the commercial building. However, only one leach field is shown in the rear.

4. Levels and grades where substantial excavation or fill is involved.

There is no apparent or proposed grading for the site. It is assumed that some minor grading will need to occur for the driveways and parking areas.

5. Clearing limits used to calculate both the volume and rate of surface water runoff.

No clearing appears to be proposed.

Site Visit Notes

On Wednesday, June 1, 2020, the Director conducted a brief site visit and determined the following:

1. The driveway serving the residence is in poor shape and has broken asphalt.
2. The solid waste container is not identified on the plan and there is currently a large solid waste dumpster on the site.
3. The commercial buildings are in very poor shape with paint peeling and deteriorated siding and doors/windows.
4. The site itself is undergoing significant site work for the septic tank and presumably for other purposes.
5. There are several mature trees on the site itself which should be retained.

B. Design Review, Applicability, Procedure, and Purpose

Not applicable to this project as it does not propose any new development. However, the Planning Board may wish to require elevation drawings and other sign details.

Note that the Commercial District Design Guidelines do not currently address signage, which is an oversight. Additionally, Protective Bylaw sign requirements do not specify what kind of sign submittal package is required, if any. Given that this is a Special Permit, The Director recommends that the Planning Board require some or all of the following from the applicant:

1. Appropriately scaled drawing showing the location of the sign; submit two (2) 8" X 10" or 11"X 17" copies. Alternatively, this information may be provided on the site plan.
 - a. If the sign is to be mounted, please include a description of the structure on which the sign will be mounted and provide photographs of the structure and the sign will be.
 - b. If the sign will be free-standing either on the property if off the premises, submit a plot plan showing the exact height and location above natural grade.

- c. A scaled rendering including dimensions, with proposed sign shown in color or with color chips attached. Submit two (2) copies; size can range from 8"X10" to 11"X17".
- d. A detailed description of the proposed sign materials and lighting. The lighting description must specify whether the sign will be illuminated with interior or exterior lighting and include information on bulb wattage

Director Comments 6/15/2020

- 1. Sign proposed to be a re-facing of pole sign and wall sign. It was recommended that the Board determine whether they wish to see the renderings prior to approval or have them administratively approved as a condition of the approval. I will write the decision as per the latter.
- 2. Section 125-38F1 explicitly states that "site plan applications for proposed development in the Commercial 'C' District shall include renderings of the proposed building(s) or addition..." Given that this application is for rehabilitation and reuse, the Board may wish to relax or waive this requirement, but it is for the Board's discretion.

C. Landscape Plan

Applicant should show any landscaping to be proposed. There are several mature trees on site which should be preserved. It was recommended that the remainder of the site be thoughtfully landscaped with grass and native plantings adjacent to buildings and parking areas.

Director Comments 6/15/2020

- 1. Recommend that any additional landscaping be depicted on a revised plan as Section 125-38G is clear that a landscape plan is a requirement for site plans unless the Board wishes to relax or waive. Relaxation could be allowing the applicant to include landscaping features on the site plan itself.
- 2. Director recommended that areas on site to be hydro seeded should be so depicted.
- 3. Landscaping materials provided on revised plan seem sufficient.

IV. Site Standards (Section 125-39)

A. Parking and Loading

- 1. No shared parking, loading, or other traffic areas is being proposed. Not recommended for this scale of review.
- 2. While proposed parking areas are highlighted, the Planning Board may wish to get further information related to 1) whether the tandem parking is satisfactory or how it will be administered. It appears as though the site could accommodate a travel lane between the two rows and if so, that would be staff recommendation, and 2) How the drives are to function related to accessing each use.

3. Parking areas not to the scale that would require subdivision or interspersed green landscaped areas. Parking stalls are proposed to be 9'x19' and the tandem parking is 9' x 20'. Car stops were not proposed in the plan but the Director recommended that they be considered for the gravel parking area.
4. The plan does not show where waste receptacles (dumpster) will be located and it was recommended by the Director that the applicant show appropriate screening (for commercial building). The applicant stated that there would be no commercial waste receptacles.
5. Plan review could not assess whether parking spaces to be provided would be enough for the proposed use but that it would be important to make that determination provided there are no special events, clinics, etc. For the latter, the Board was recommended to ask the applicant if they may need overflow parking areas for such events and where that would be staged. The Director also recommended that visitors or staff not park along the driveway due to safety and aesthetics. The Director also suggested that the Board consider requesting the applicant to provide examples of parking standards for such uses in other communities.

Director Comments 6/15/2020

1. Recommend against tandem parking. The Director recommended that the Plan be revised to eliminate these spaces. The applicant agreed with this provision and the revised site plan was so modified.
2. Recommend 6' commercial parking block for all gravel spaces.
3. Recommend paved parking spaces, including handicapped, to be appropriately striped.
4. Cannot assess whether 10 spaces are sufficient for use.

B. Standards for Driveways

1. It is not clear whether existing driveways meet the AASHTO line of sight criteria. These are existing driveways but there may be more cars that access the site and it was recommended that this should be addressed by the applicant to ensure traffic safety entering and exiting the site. This criterion was not addressed.
2. Non-residential driveway standards
 - a. Standards recommend only one ingress-egress point but existing lot has two.
 - b. No trip generation data is recommended but it was recommended that the applicant speak to expected motor vehicular traffic anticipated on a daily basis and the timing of said traffic.

- c. While a formal 10% buffer strip around the perimeter of the lot has not been established, the aerial photograph of the site indicates a setback of at least 10' that is grassy with trees along the north border of the property.
- d. No inter-parcel connectivity is proposed.
- e. It was recommended that the Applicant speak to whether the angle of intersection of the driveway center line is at least 60° and that the transition is sufficiently flared for required turn movements. This was not addressed.
- f. Regarding construction, as no new development is being proposed, no construction or reconstruction is required unless the transition(s) are found to be deficient.
- g. The 30' turnaround for "circular" driveway appears to be met. The "runout" ratio also appears to be compliant.

Director 6/15/2020 Comments

- 1. No further line-of-sight comments. Prior comments stand.
- 2. It was recommended that anticipated driveway directional travel be depicted on plan—if narrower southern driveway still recommended for two-way travel, it would be more effective to be limited to residential use and signed to reflect this.
- 3. It was recommended that the applicant speak to whether the angle of intersection of the driveway center line is at least 60° and that the transition is sufficiently flared for required turn movements.

C. Open Areas

- 1. Buffer strip requirement appears to be met in principle or mimicked on the ground.
- 2. The 50% minimum green area appears to be met.

D. Screening

No existing or proposed lighting is shown on the plan and the Board was recommended to determine whether these should be added. As this property is surrounded by other commercial properties, it was determined that the Board may wish to exclude the screening requirement. If not, the applicant must meet the requirements of subsections D(4) and D(5).

E. Fire Protection

Not an applicable provision for this site.

F. Drainage

No new building construction is proposed and only some additional gravel and asphalt is being introduced to the site and therefore stormwater is not anticipated to change significantly. Agree with applicant's consultant that there will likely be no substantial increase in runoff.

G. Sidewalks

While the Bylaw says that any use subject to site standards shall provide sidewalk and curbing, this certainly cannot pertain to changes in tenancy with little site development. I would suggest that this provision is not applicable in this instance.

6/15/2020 Director Update

Director spoke at length to the DPW Director and advised that, particularly with the Ayer Road project being in design, that no other sidewalk projects be undertaken at this time. He was also opposed to gravel paths which he said could devolve into parking areas on the shoulder. He was, however, in favor of a payment-in-lieu condition for site plans and special permits for properties that were reviewed for design guidelines in the Ayer Road corridor.

H. Section 125-40, Lighting

The applicant notes that no additional lighting is being proposed either attached to buildings or on poles.

I. Section 125-41, Signs

There are no existing signs on the property and it is assumed that a business sign will be installed. It was recommended that there at least be an elevation drawing for the sign.

6/15/2020 Director Update

Section 125-38D1 explicitly states that existing and proposed signs shall be indicated on the site plan. Section 125-38F2f notes that the "use of pedestrian-scale lighting and signage" is required. As a special permit, the Board may request a signage package from the applicant in advance of seeking permits for the signs and within this review. However, it is not required.

DECISION

After reviewing the Application, plans, and other materials and information submitted, comments by the Director of Community and Economic Development, comments by other Town officials, responses by the applicants consulting engineer, testimony given at the public hearing, the Board made the above-referenced findings of fact and, based on those findings, the Board hereby decides that the Property is suitable for an indoor athletic facility pursuant to §125-14 of the Town of Harvard Protective Bylaw and that all the required criteria for a Special Permit has been met. Accordingly, the Board hereby grants a Special Permit and approves the accompanying Site Plan to Scott Peterson for an indoor athletic facility, pursuant to §§125-1, 125-2, 125-14, 125-38, 125-39, and 125-46 of the Town of Harvard Protective Bylaw in accordance with the terms and conditions stated below.

TERMS AND CONDITIONS

Standard Conditions

- I. This Special Permit shall lapse no later than June 15, 2022, but shall not include such time required to pursue or await the determination of an appeal referenced to in M.G.L. Chapter 40A, §17, if substantial use of the Special Permit has not sooner commenced except for good cause or, in the case of a permit for construction, if construction has not begun by such date except for good cause.
- II. The site plan accompanying this Special Permit application shall be incorporated into this decision and shall be a standard condition of this approval.
- III. The granting of this Special Permit and site plan approval, and the project which is the subject of the Special Permit and accompanying site plan, including all construction and subsequent operations, is predicated on the applicant complying fully with all provisions of the Town of Harvard Protective Bylaw, the Code of the Town of Harvard, and Massachusetts General Law, as applicable.
- IV. The applicant shall be responsible for acquiring and complying with all other local, state, or federal permits and approvals as necessary to construct and operate the project as approved by the Board.
- V. This Decision and accompanying site plan shall be recorded by the applicant at the Worcester County Registry of Deeds. A copy of the recorded Decision and site plan shall be submitted to the Planning Board prior to commencing construction.
- VI. The applicant shall provide to the Planning Board, Building Commissioner, and Fire Chief, a detailed construction schedule identifying the sequence and timetable of all key components of the proposed construction activity, as applicable.
- VII. Duly authorized agents of the Town shall have the right to enter upon the Property to ensure continued compliance with the terms and conditions of this Special Permit.
- VIII. This decision allows the proposed improvements and activities in the location shown on the approved site plan. No alterations, changed to the approved improvements, other additional uses or additional improvements shall be allowed without further review and approval by the Planning Board in the form of a modification to the Special Permit.

Special Conditions

The following Special Conditions were voted affirmatively by the Planning Board at their regular meeting of June 15, 2020:

- I. Adherence to all standard conditions of approval for site plans.
- II. That the applicant offers the Town a payment-in-lieu, rather than providing the 6' concrete sidewalk specified in the Section 125-39G(1) on a cost per linear foot of \$15.13 and on a 5' width. In this case, a payment would translate to \$4000 to be deposited in an escrow

account dedicated to this site or on the opposite side to be determined at the 75% design phase of the Ayer Road project.

- III. That the applicant be prohibited from tandem parking spaces on the property.
- IV. That the applicant provides an as-built site plan upon completion of project prior to final inspection.
- V. That the applicant seeks and receives a driveway permit from DPW.
- VI. That if any commercial scale waste receptacle is deemed necessary in the future, that the applicant submit plans for the receptacle to the Planning Board for approval.

VOTE

The following members of the Board voted to grant the Special Permit, subject to the above stated terms and conditions:

- I. Erin McBee, Chair
- II. Stacia Donahue
- III. Frances Nickerson
- IV. Justin Brown

The following members voted to deny the grant of a Special Permit:

None

ELECTRONIC SIGNATURE

The Harvard Planning Board, on May 18, 2020, voted to authorize the Director of Community and Economic Development, to electronically sign Harvard Planning Board documents during the Covid-19 State of Emergency as per the provisions of M.G.L. Chapter 110G, which the Planning Board recognizes and accepts heretofore throughout the duration of the emergency.

Recorded at the Worcester South District Registry of Deeds as an Electronically Recorded Document Book 62538, Page 390:

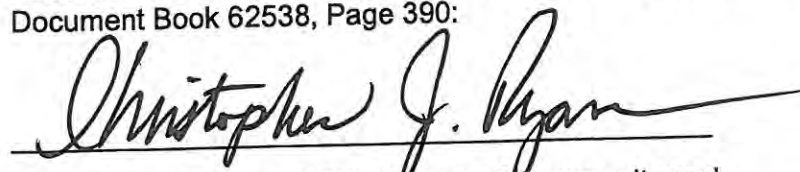

Christopher J. Ryan, AICP, Director of Community and Economic Development

This decision is not valid until after it has been certified with respect to an Appeal by the Harvard Town Clerk, as provided in MGL, Chapter 40A Section 11, and a copy as certified has been recorded in the Worcester Registry of Deeds.

An Appeal of this decision may be made pursuant to MGL Chapter 40A Section 17 within twenty (20) days after the decision is filed with the Town Clerk.

This is to certify that as of July 28, 2020 no notice of appeal has been filed with this office in regard to this decision.

Signed: 

~~Marlene Kenney, Town Clerk~~
~~Catherine Bowen, Asst.~~



N/F
DKMP REALTY LLC

Plant List

TREES/SHRUBS				
Symbol	No.	Botanical Name	Common Name	Size
HB	1	Hibiscus syriacus	Blue Satin	3'-4'
PJM	6	Rhododendron PJM	PJM Rhododendron	2'-3'
PF	6	Potentilla fruticosa Pink Beauty	Pink Beauty	18"-24"
JS	5	Juniperus chinensis "Seagreen"	Seagreen Juniper	18"-24"
CS	6	Cotoneaster salicifolius "Scarlet Leader"	Willowleaf Cotoneaster	12"-18"
IC	6	Ilex crenata "Compacta"	Compact Japanese Holly	18"-24"

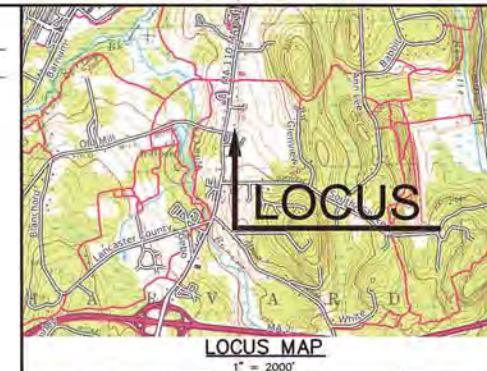

ELEVATION DATUM
DATUM: ASSUMED



PLAN REFERENCES

- "SUBSURFACE SEWAGE DISPOSAL SYSTEM-UPGRADE-256 AYER ROAD HARVARD, MA" PREPARED FOR SCOTT PATTERSON BY GOLDSMITH, PREST & RINGWALL, INC. DATED NOVEMBER 2019. REVISED THROUGH 12/17/2019.
- "HARVARD-IN THE BATTER'S BOX-WS37 SITE APPROVAL" PREPARED FOR 256 AYER ROAD, LLC. BY MASSACHUSETTS DEPARTMENT OF ENVIRONMENTAL PROTECTION. DATED MARCH 31, 2020.

ASSESSORS REFERENCE:

ASSESSORS MAP 04, BLOCK 41
RECORD OWNER:
256 AYER ROAD, LLC.
11 SPRING STREET
LUNENBURG MA, 01462

EXISTING CONDITIONS NOTES:

- EXISTING CONDITION INFORMATION BASED ON AN ON-THE-GROUND TOPOGRAPHIC SURVEY PERFORMED BY GOLDSMITH, PREST & RINGWALL, INC. DATED SEPTEMBER 27, 2019.

DRAWING ISSUED FOR:

- CONCEPT CONSTRUCTION
 PERMIT CONSTRUCTION RECORD



THIS DRAWING MAY NOT SHOW CONSTRUCTION DETAILS AND SPECIFICATIONS FOR ALL PROPOSED IMPROVEMENTS, AND MAY NOT IDENTIFY ALL CONSTRUCTION WORK ITEMS/AREAS OF CONTRACTOR JURISDICTION.

PER 250 CMR 5.03(13), THE FOLLOWING ARE EXCLUDED FROM THE PROFESSIONAL ENGINEER'S RESPONSIBILITY: ALL BOUNDARY INFORMATION; LOCATION OF EXISTING STRUCTURES, TREES, UTILITIES, TOPOGRAPHY OR SIMILAR FEATURES; DESIGN OF RETAINING WALLS, PROPRIETARY EQUIPMENT. SEE EXISTING CONDITION NOTES.

NO.	DATE	BY	APP.	REVISION DESCRIPTION
1	06/09/20	MCL	NMP	PLANNING BOARD MEETING DISCUSSION

GPR Engineering Solutions
for Land & Structures

GOLDSMITH, PREST & RINGWALL, INC.

39 MAIN STREET, SUITE 301, AYER, MA 01432
CIVIL ENGINEERING • LAND SURVEYING • LAND PLANNING
VOICE: 978.772.1590 FAX: 978.772.1591
www.gpr-inc.com

SPECIAL PERMIT
LARGE SCALE COMMERCIAL USES
SITE PLAN & CONSTRUCTION
DETAILS

256 AYER ROAD
HARVARD, MA

PREPARED FOR:
256 AYER ROAD, LLC.
11 SPRING STREET
LUNENBURG, MA 01462

DES. BY: MCL DATE: APRIL 2020 JOB 181090 1 OF 1
CHK. BY: NMP

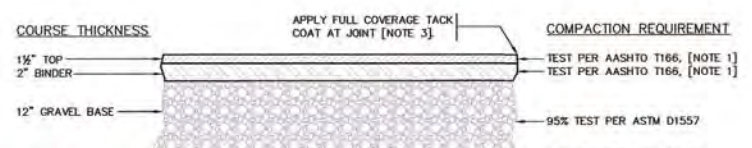
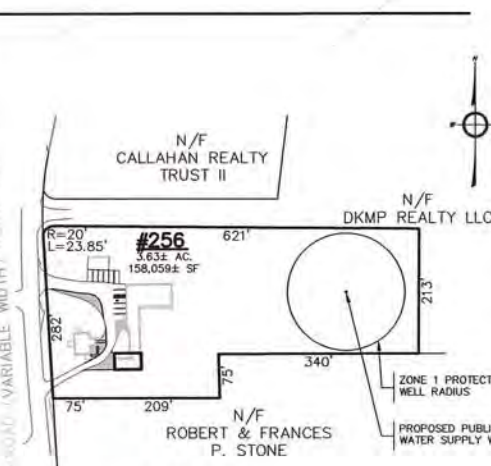
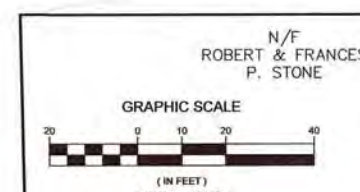
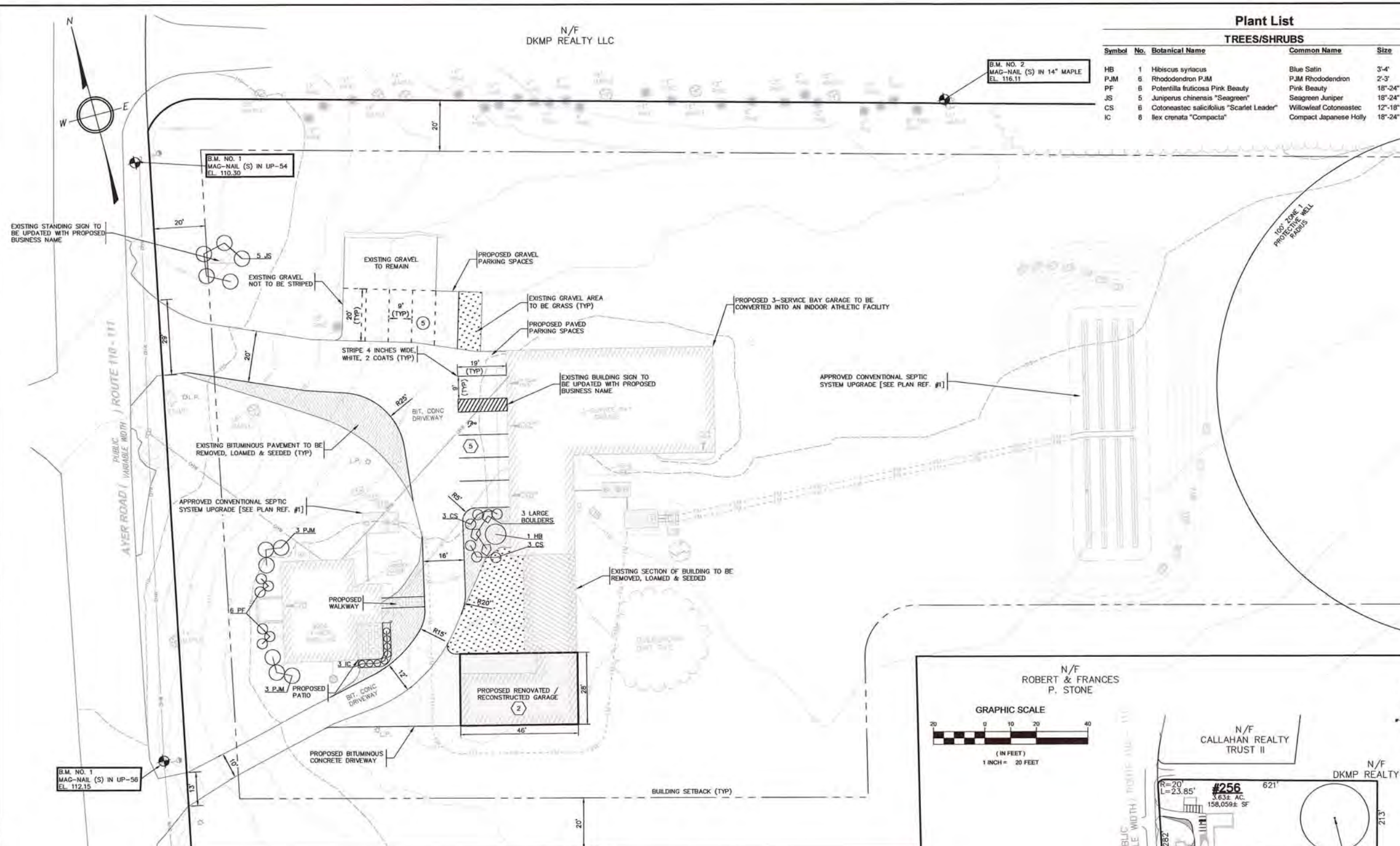

COURSE	MATERIAL	SPECIFICATION PER MASS HIGHWAY DEPARTMENT (MHD)	MAX AGG. SIZE (INCH)
TOP	BITUMINOUS CONCRETE	M3.11.03 CLASS I, TYPE I-1	1 1/2
BINDER	BITUMINOUS CONCRETE	M3.11.03 CLASS I, TYPE I-1	3/4
BASE	GRAVEL BORROW [2]	M1.03.0 TYPE B	3
UNSATURABLE SUBGRADE	ORDINARY BORROW	ON-SITE EXCAVATED MATERIAL	12

- NOTES:**
[1] COMPACT TO TEST AVERAGE OF 95% NO TEST LOWER THAN 93%.
[2] ACCEPTABLE SUBSTITUTE MATERIAL: 3/4" MINUS DENSE GRADED CRUSHED STONE.
[3] EXISTING PAVEMENT SHALL BE SAW CUT VERTICALLY AT FINAL JOINT LOCATIONS.

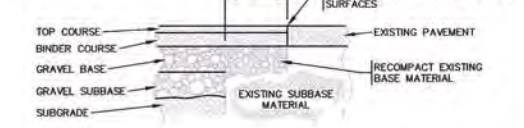

- NOTES:**
[1] FLEXIBLE PAVEMENT REMOVAL SHALL BE INITIATED BY MAKING A FULL-DEPTH VERTICAL SAWCUT AT THE LOCATIONS INDICATED ON THE PLANS. SAWCUTS SHALL BE ACCOMPLISHED USING A STANDARD DIAMOND-TYPE BLADE SAW.
[2] IF SAWCUT IS WITHIN THREE (3) FEET OF AN EXISTING BUILDING, CURB LINE OR EXISTING FENCE, COMPLETELY REMOVE EXISTING PAVEMENT AND REPLACE ACCORDING TO THE REQUIREMENTS OF THE BITUMINOUS CONCRETE PAVEMENT SECTION.

COVERAGE COMPUTATIONS:

PARAMETER	AREA (ACRES)	AREA (SQ. FEET)	FRACTION OF TOTAL LOT AREA (%)
EXISTING CONDITION			
Lot Area	3.63±	158,060±	100%
Building Footprint	0.18±	7,614±	4.8%
Other Impervious Area	0.19±	8,450±	5.3%
Gravel Coverage (Pervious)	0.07±	3,060±	1.9%
Total Impervious Coverage	0.37±	16,064±	10.1%
Total Open Green Area	3.19±	138,936±	87.9%
DEVELOPED CONDITION			
Lot Area	3.63±	158,060±	100%
Building Footprint	0.16±	7,069±	4.5%
Other Impervious Area	0.18±	7,924±	5.0%
Gravel Coverage (Pervious)	0.04±	1,861±	1.2%
Total Impervious Coverage	0.34±	14,993±	9.5%
Total Open Green Area	3.24±	141,206±	89.3%

PARKING TABLE:

PARAMETER	SPACES
PUBLIC PARKING	
Gravel Parking	5
Paved Parking	5
PRIVATE PARKING	
Garage Spaces	2
TOTAL PARKING	12

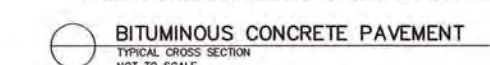

P:\181090\DWG\PERMIT\SP_SITE_PLAN.DWG 06-09-20 11:16:58 AM - LAYOUT SP-SITE PLAN

2020 © COPYRIGHT GOLDSMITH, PREST & RINGWALL, INC.

OFFICE OF THE
PLANNING BOARD

13 AYER ROAD HARVARD, MA 01451

978-456-4100

www.harvard-ma.gov



To: Lynn Kelly, Town Clerk
Harvard Town Hall
13 Ayer Road
Harvard, MA 01451

APRIL 25, 2022

HARVARD PLANNING BOARD

**NOTICE OF DECISION ON APPLICATION OF SCOTT
PATTERSON FOR A MODIFICATION TO A SPECIAL
PERMIT AND SITE PLAN APPROVAL FOR THE
ESTABLISHMENT OF AN INDOOR ATHLETIC FACILITY
AT**

256 AYER ROAD

HARVARD, MA 01451

ASSESSORS MAP 4 – PARCEL 41

WORCESTER REGISTRY OF DEEDS

BOOK 59556 PAGE 235

RECEIVED
HARVARD TOWN CLERK
2022 MAY -9 AM 11:37

PROCEDURAL HISTORY

- I. Application for the modification of a previously issued Special Permit and Site Plan for an indoor athletic facility as per §125-14, Large-scale commercial uses, of The Protective Bylaw, for the property located at 256 Ayer Road was made on March 7, 2022 by the above referenced applicant.
- II. The following plans and documents were submitted in support of the application:
 - A. An application for a Modification to a Special Permit and site plan review with a Special Permit for an indoor athletic facility pursuant to §125-14 of the Town of Harvard Protective Bylaw was received by the Harvard Town Clerk on March 7, 2022, including a cover letter from Nicholas Pauling, P.E. of Goldsmith, Prest, & Ringwall, Inc. (GPR) dated March 7, 2022 and the following:
 - 1. Corresponding fee of \$340.00
 - 2. A document entitled "Special Permit Modification, 256 Ayer Road, Harvard, MA", which also included:

- a. Application form referenced above
 - b. Cover letter referenced above
 - c. Certified abutters list report dated February 2, 2022
- B. A plan set dated March 7, 2022 entitled "Special Permit, Large Scale Commercial Uses, Site Plan & Construction Details, 256 Ayer Road, Harvard, MA" prepared for applicant Scott Patterson, 11 Spring Street, Lunenburg, MA 01462, by Goldsmith, Prest, & Ringwall, Inc., 39 Main Street, Suite 301, Ayer, MA 01432, JOB 181090, containing one (1) sheet.
- C. A revised plan set dated April 13, 2022 entitled "Special Permit, Large Scale Commercial Uses, Site Plan & Construction Details, 256 Ayer Road, Harvard, MA" prepared for applicant Scott Patterson, 11 Spring Street, Lunenburg, MA 01462, by Goldsmith, Prest, & Ringwall, Inc., 39 Main Street, Suite 301, Ayer, MA 01432, JOB 181090, containing one (1) sheet.
- D. A letter dated April 20, 2022 from Nicholas Pauling, P.E. of Goldsmith, Prest, & Ringwall, Inc. (GPR) providing a narrative for the revised site plan referred to in C. above.
- E. Graphic entitled "Athletic Barn Addition" dated April 21, 2022 depicting proposed rear and side elevations of building expansion.
- F. Photographs of relocated dumpster.
- III. The following additional documents were provided to the Planning Board in regard to the application:
- None
- IV. Legal Notices: Advertised and Letters to Abutters
- A. An Affidavit of Mailing to Abutters dated May 12, 2020 was endorsed by the Assistant Town Clerk on March 15, 2022.
 - B. A Legal Notice dated March 8, 2022 advertising the virtual public hearing to be held on April 4, 2022 on the Special Permit for the operation of an indoor athletic facility appeared in "The Harvard Press" on March 18, 2022 and March 25, 2022.
- V. A public hearing, after proper notice was given, was opened on April 4, 2022 and closed on May 2, 2022.
- VI. Public Input

At public hearing sessions held on April 4, 2022, April 25, 2022, and May 2, 2022, the representatives of the applicant attended including Bruce Ringwall.

Members of the public attending public hearings: None.

BACKGROUND AND FINDINGS

The Harvard Planning Board reviewed the application, the plan sets, and all other materials and information submitted prior to the close of the public hearing. The Board received and gave due consideration to the testimony given at the public hearing. The following is a compilation of the comments provided by the Director in review of the application and plans.

I. General

- A. The subject property is a 3.63 ± acre parcel (3.54 acres on GIS) within a Commercial (C) zoning district and the land use is commercial and residential with 2 existing buildings (commercial at 6086 s.f. and residential at 1966 s.f.).
- B. The applicant is seeking a modification to the previously approved Special Permit and Site Plan Approval which included an enlargement of the garage building and the establishment of a paved apron from the driveway to the garage.
- C. For this modification, the applicant no longer is seeking to develop a garage building and driveway apron and instead proposes to build an 1,956 s.f. addition to the existing "Barn" structure. The applicant also proposes to expand the parking area as depicted on the revised plan dated April 13, 2022 and relocate the solid waste receptacle to an area adjacent to the parking area and directly behind the mature spruce tree, also as noted on the April 13th plan.

II. Findings

A. Comments From Other Town Boards or Staff

None

B. Special Permit Criteria

1. Special Condition IV of the original decision required the Applicant to provide an as-built site plan "upon completion of the project and prior to final inspection." This was not met, but the Planning Board was willing to allow the Applicant to provide a plan set sheet with that information provided.
2. Remaining Standard and Special Conditions of original decision were met.
3. No other Special Permit criteria deemed relevant for this application.

C. Site Plan Review Criteria

1. Staff report recommended relocation of solid waste receptacle to an area behind the residence. The Applicant noted that the "Barn" would also be users of the receptacle. The Board agreed that the proposed placement was more appropriate given that information.

2. The Planning Board was satisfied with the existing tree serving as adequate screening for the solid waste receptacle but wanted assurance in the event that the tree was no longer viable, that the applicant provided a three-sided fence or some other ameliorative measure. The Applicant was willing to agree to a Special Condition to replace the unviable tree with equivalent screening coverage.
3. Regarding the need for site lighting, the Applicant asserted that the bulk of the business was conducted during the afternoon and early evening and that no parking lot lighting would be necessary. There were no Standard or Special Conditions relating to hours of operation for the business.
4. Related to the Commercial Design Guidelines, the Planning Board elected to conduct an internal design review rather than require the Applicant to go through the Design Review Board due to the scale and visibility of the proposed addition.

DECISION

After reviewing the Application, plans, and other materials and information submitted, comments by the Director of Community and Economic Development, comments by other Town officials, responses by the applicants consulting engineer, testimony given at the public hearing, the Board made the above-referenced findings of fact and, based on those findings, the Board hereby decides that the Property is suitable for an indoor athletic facility pursuant to §125-14 of the Town of Harvard Protective Bylaw and that all the required criteria for a Modification to a Special Permit have been met. Accordingly, the Board hereby grants a Special Permit and approves the accompanying Site Plan to Scott Peterson for an indoor athletic facility, pursuant to §§125-1, 125-2, 125-14, 125-38, 125-39, and 125-46 of the Town of Harvard Protective Bylaw in accordance with the terms and conditions stated below.

TERMS AND CONDITIONS

Standard Conditions

- I. This Special Permit shall lapse no later than May 2, 2024, but shall not include such time required to pursue or await the determination of an appeal referenced to in M.G.L. Chapter 40A, §17, if substantial use of the Special Permit has not sooner commenced except for good cause or, in the case of a permit for construction, if construction has not begun by such date except for good cause.
- II. All prior Standard and Special Conditions as part of the 2020 Decision shall be adhered to.
- III. The site plan accompanying this application shall be incorporated into this decision and shall be a Standard Condition of this Decision.
- IV. The granting of this Modification to a Special Permit and Site Plan Approval, and the project which is the subject of the Special Permit and accompanying site plan, including all construction and subsequent operations, is predicated on the applicant complying fully with all provisions of the Town of Harvard Protective Bylaw, the Code of the Town of Harvard, and Massachusetts General Law, as applicable.

- V. The applicant shall be responsible for acquiring and complying with all other local, state, or federal permits and approvals as necessary to construct and operate the project as approved by the Board.
- VI. This Decision and accompanying site plan shall be recorded by the applicant at the Worcester County Registry of Deeds. A copy of the recorded Decision and site plan shall be submitted to the Planning Board prior to commencing construction.
- VII. The applicant shall provide to the Planning Board, Building Commissioner, and Fire Chief, a detailed construction schedule identifying the sequence and timetable of all key components of the proposed construction activity, as applicable.
- VIII. Duly authorized agents of the Town shall have the right to enter upon the Property to ensure continued compliance with the terms and conditions of this Special Permit.
- IX. This decision allows the proposed improvements and activities in the location shown on the approved site plan. No alterations, changed to the approved improvements, other additional uses or additional improvements shall be allowed without further review and approval by the Planning Board in the form of a modification to the Special Permit.

Special Conditions

The following Special Conditions were voted affirmatively by the Planning Board at their regular meeting of May 2, 2022:

- I. The final architectural drawings and renderings of the building addition shall be reviewed by the Planning Board prior to seeking a Building Permit.
- II. Complete the landscape plantings at the front of the residence as shown on the original 2020 Site Plan prior to seeking a Certificate of Occupancy for the building addition.
- III. No new exterior lighting shall be established on site without a modification to this Special Permit and Site Plan Approval.
- IV. If the existing mature evergreen tree currently screening the solid waste receptacle were to be damaged or expire, the Applicant shall, at the earliest reasonable date after the tree was no longer serving as an appropriate screening mechanism, replace the tree with landscape vegetation of equivalent or better screening capacity, as long as the receptacle was in this location.
- V. The Applicant shall provide suitable wheel stops for each of the designated 28 parking spaces.

VOTE

The following members of the Board voted to grant the Special Permit, subject to the above stated terms and conditions:

- I. Justin Brown, Chair
- II. Richard Cabelus, Vice-Chair

- III. Stacia Donahue
- IV. Brian Cook
- V. Doug Thornton

The following members voted to deny the grant of a Special Permit:

None

By a unanimous vote of five (5) members of the Planning Board, the application for Modification of a Special Permit and Site Plan Approval is **APPROVED** subject to the Conditions and Limitations contained herein.

RECORDING

This decision shall be recorded with the Worcester District Registry of Deeds and a recorded copy shall be furnished to the Planning Board and Building Commissioner within 30 days after the expiration of the appeal period as set forth in M.G.L. c. 40A, §17.

Appeals may be made pursuant to M.G.L. c. 249 §4 and shall be filed within twenty (20) days after the date this Decision is filed with the Town Clerk.

Recorded at the Worcester South District Registry of Deeds Book _____, Page _____:



 Justin Brown, Chair



 Richard Cabelus, Vice-Chair

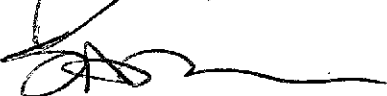

 Stacia Donahue

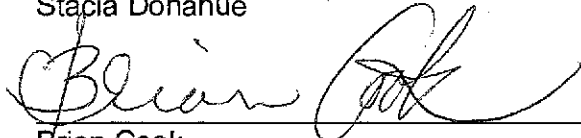

 Brian Cook



 Doug Thornton

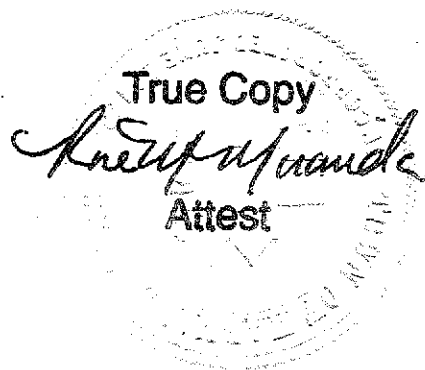

This is to certify that as of January 18, 2024 no notice of appeal has been filed with this office in regard to this decision.

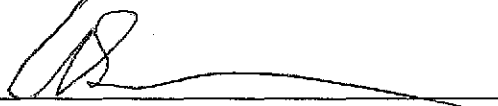
Signed: 

 Lynn Kelly, Town Clerk
 Andrew J. Sammarco, Assistant Town Clerk

252 W. Adams, P.O. Box 399 • Morton, Illinois 61550-0399

306 36'x16'x70' West and South Walls



252 W. Adams, P.O. Box 399 • Morton, Illinois 61550-0399

306 36'x16'x70' East and North Walls

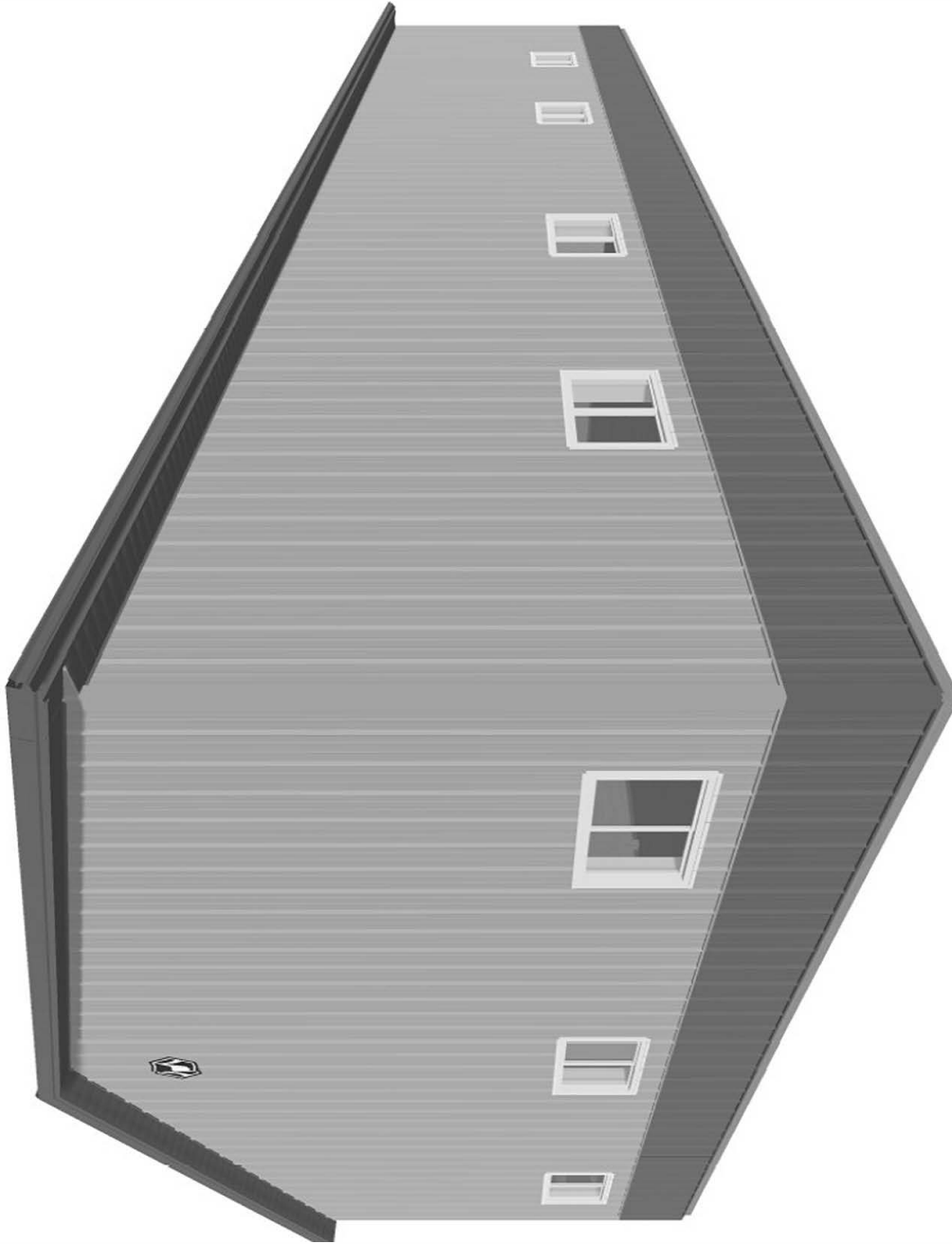

252 W. Adams, P.O. Box 399 • Morton, Illinois 61550-0399

306 36'x16'x70' (#1) Column Plan

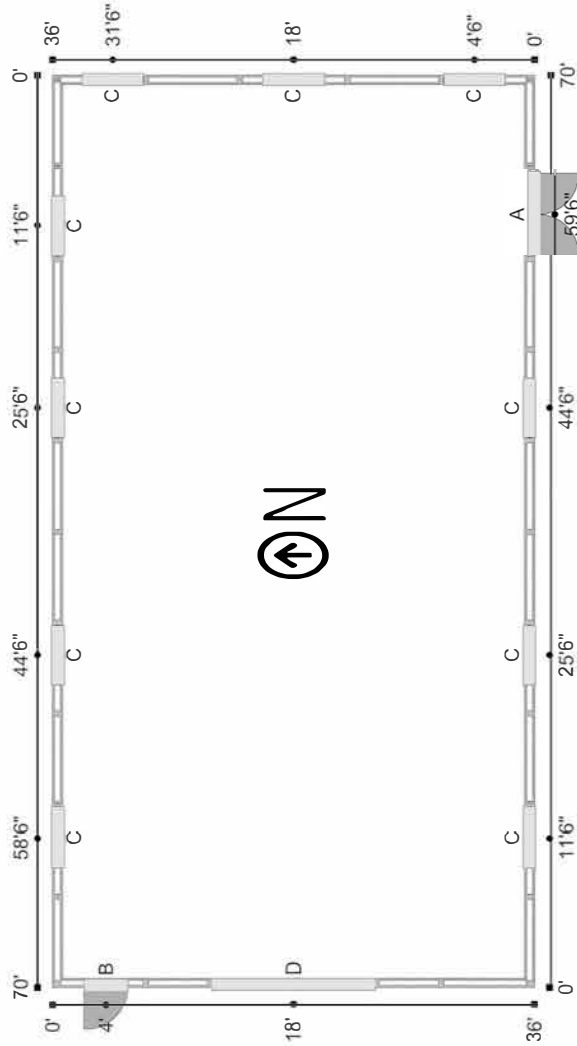

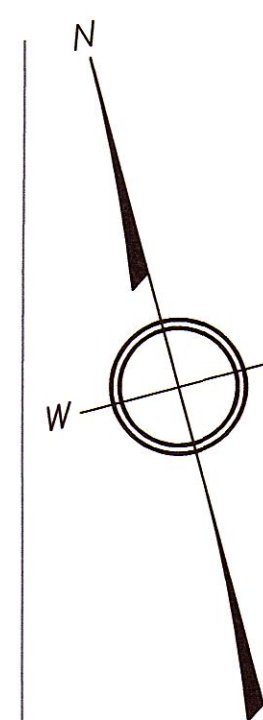

STORMWATER MANAGEMENT:
ROOF AREA SUMMARY
 PREVIOUSLY APPROVED, NOT CONSTRUCTED (ATTACHED FACILITY) = 1,956 SF
 PROPOSED (DETACHED WORKOUT FACILITY) = 2,520 SF
 INCREASE IN ROOF AREA = 564 SF
STORMWATER VOLUME GENERATED = [RECHARGE] X [PROPOSED INCREASE IN ROOF AREA]
 [1 IN (1.0 FT/12.0 IN)] X [564 S.F.] = 47 C.F.±
PROVIDED INFILTRATION VOLUME
 (CRUSHED STONE DRIP EDGE) = 2' (W) X 2' (D) X 70' (L) X 40% (CRUSHED STONE VOIDS) = 112 C.F.±

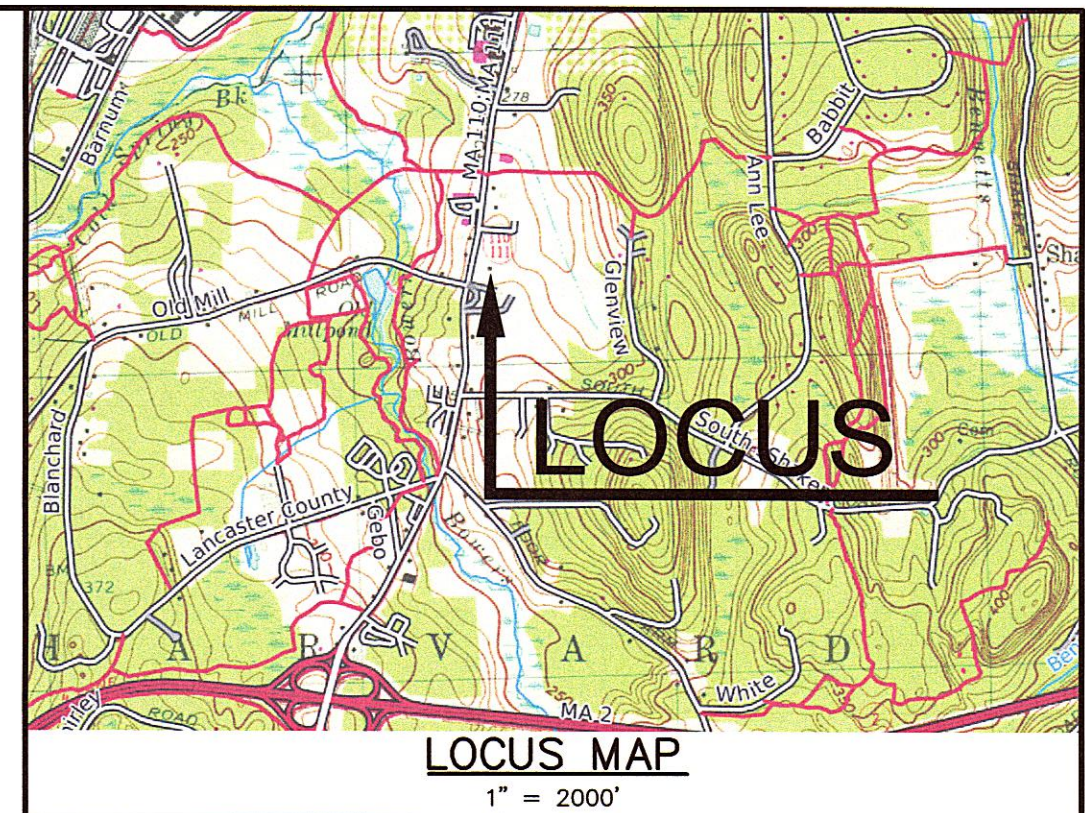

ELEVATION DATUM
 DATUM: ASSUMED

- PLAN REFERENCES**
- "SUBSURFACE SEWAGE DISPOSAL SYSTEM - UPGRADE - CONSTRUCTION RECORD DRAWING - 256 AYER ROAD HARVARD, MA" PREPARED FOR SCOTT PATTERSON BY GOLDSMITH, PREST & RINGWALL, INC. DATED OCTOBER 2020.
 - "NOTICE OF DECISION ON APPLICATION OF SCOTT PATTERSON FOR A SPECIAL PERMIT AND SITE PLAN APPROVAL FOR THE ESTABLISHMENT OF AN INDOOR ATHLETIC FACILITY AT 256 AYER ROAD, HARVARD, MA 01451, ASSESSORS MAP 4 - PARCEL 41" DATED JUNE 15, 2020, ON FILE AT THE WORCESTER REGISTRY OF DEEDS BOOK 59556 PAGE 235.
 - "SPECIAL PERMIT - LARGE SCALE COMMERCIAL USES - SITE PLAN & CONSTRUCTION DETAILS - 256 AYER ROAD HARVARD, MA" PREPARED FOR SCOTT PATTERSON BY GOLDSMITH, PREST & RINGWALL, INC. DATED APRIL 2020, REVISED THROUGH JUNE 2020.
 - "HARVARD-IN THE BATTER'S BOX - W537 SITE APPROVAL" PREPARED FOR 256 AYER ROAD, LLC. BY MASSACHUSETTS DEPARTMENT OF ENVIRONMENTAL PROTECTION. DATED MARCH 31, 2020.
 - "SUBSURFACE SEWAGE DISPOSAL SYSTEM - UPGRADE - SINGLE COMPONENT CONNECTION - 256 AYER ROAD HARVARD, MA" PREPARED FOR SCOTT PATTERSON BY GOLDSMITH, PREST & RINGWALL, INC. DATED MARCH 2024.
 - "NOTICE OF DECISION ON APPLICATION OF SCOTT PATTERSON FOR A MODIFICATION TO A SPECIAL PERMIT AND SITE PLAN APPROVAL FOR THE ESTABLISHMENT OF AN INDOOR ATHLETIC FACILITY AT 256 AYER ROAD, HARVARD, MA 01451 ASSESSORS MAP 4 - PARCEL 41" DATED APRIL 25, 2022, ON FILE AT THE WORCESTER REGISTRY OF DEEDS BOOK 59556 PAGE 235

ASSESSORS REFERENCE:
 ASSESSORS MAP 04, BLOCK 41
 RECORD OWNER:
 256 AYER ROAD, LLC.
 11 SPRING STREET
 LUNENBURG MA, 01462

EXISTING CONDITIONS NOTES:
 1. EXISTING CONDITION INFORMATION BASED ON AN ON-THE-GROUND TOPOGRAPHIC SURVEY PERFORMED BY GOLDSMITH, PREST & RINGWALL, INC. DATED SEPTEMBER 27, 2019 AND UPDATED WITH CONSTRUCTION RECORD INFORMATION DATED SEPTEMBER 08, 2020 & 10/07/20.

DRAWING ISSUED FOR:

CONCEPT CONSTRUCTION
 PERMIT CONSTRUCTION RECORD

THIS DRAWING MAY NOT SHOW CONSTRUCTION DETAILS AND SPECIFICATIONS FOR ALL PROPOSED IMPROVEMENTS, AND MAY NOT IDENTIFY ALL CONSTRUCTION WORK ITEMS/AREAS OF CONTRACTOR JURISDICTION.

PER 250 CMR 5.03(13), THE FOLLOWING ARE EXCLUDED FROM THE PROFESSIONAL ENGINEER'S RESPONSIBILITY: ALL BOUNDARY INFORMATION; LOCATION OF EXISTING STRUCTURES, TREES, UTILITIES, TOPOGRAPHY OR SIMILAR FEATURES; DESIGN OF RETAINING WALLS, PROPRIETARY EQUIPMENT. SEE EXISTING CONDITION NOTES.

NO.	DATE	BY	APP.	REVISION DESCRIPTION
4	3/27/24	JFB	NMP	SPECIAL PERMIT & SITE PLAN MODIFICATION
3	4/13/22	JFB	NMP	PLANNING BOARD MEETING DISCUSSION
2	3/7/22	JFB	NMP	SPECIAL PERMIT & SITE PLAN MODIFICATION
1	06/09/20	MCL	NMP	PLANNING BOARD MEETING DISCUSSION

GPR Engineering Solutions for Land & Structures

GOLDSMITH, PREST & RINGWALL, INC.
 39 MAIN STREET, SUITE 301, AYER, MA 01432
 CIVIL ENGINEERING • LAND SURVEYING • LAND PLANNING
 VOICE: 978.772.1590 FAX: 978.772.1591
 www.gpr-inc.com

SPECIAL PERMIT
LARGE SCALE COMMERCIAL USES
SITE PLAN & CONSTRUCTION
DETAILS

256 AYER ROAD
HARVARD, MA

PREPARED FOR:
 256 AYER ROAD, LLC.
 11 SPRING STREET
 LUNENBURG, MA 01462

DES. BY: MCL	DATE: APRIL 2020	JOB 181090	1 OF 1
CHK. BY: NMP			

P:\181090\DWG\PERMIT\SP_SITE PLAN REVISION - 4.DWG 03-27-24 12:58:50 PM - LAYOUT SP - SITE PLAN

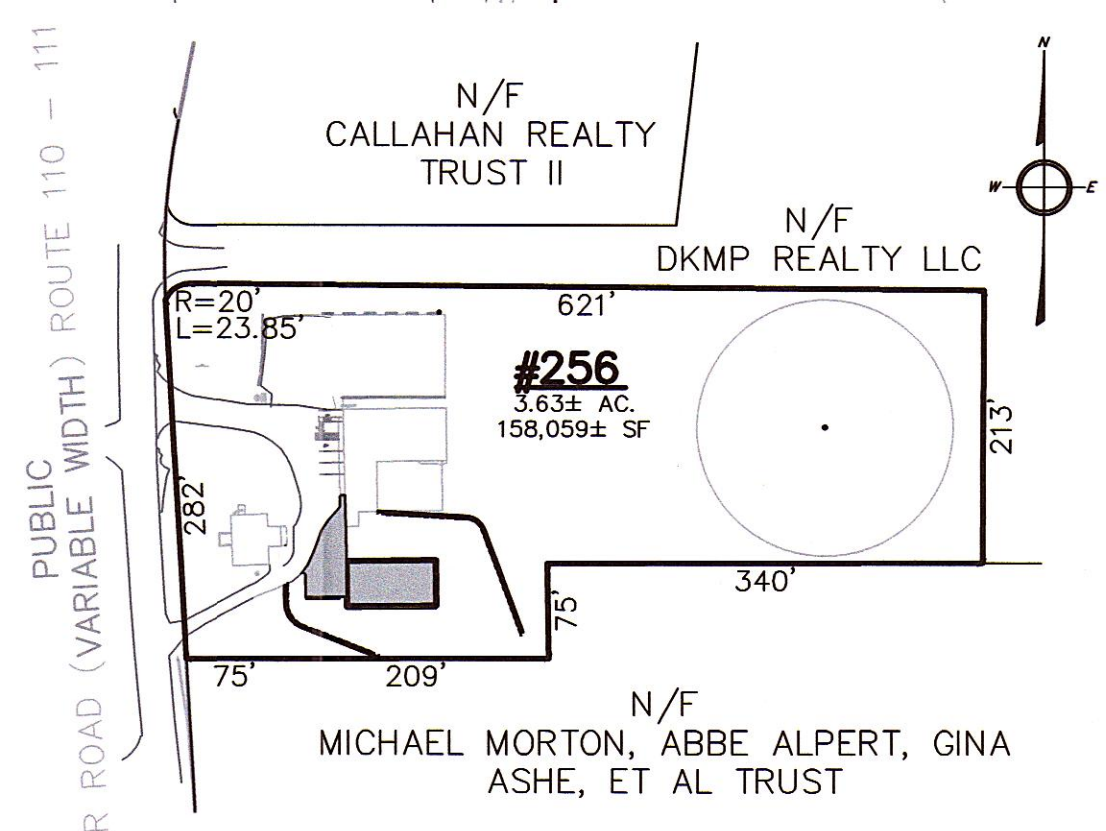
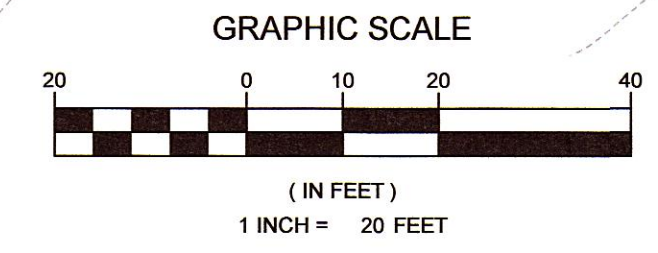
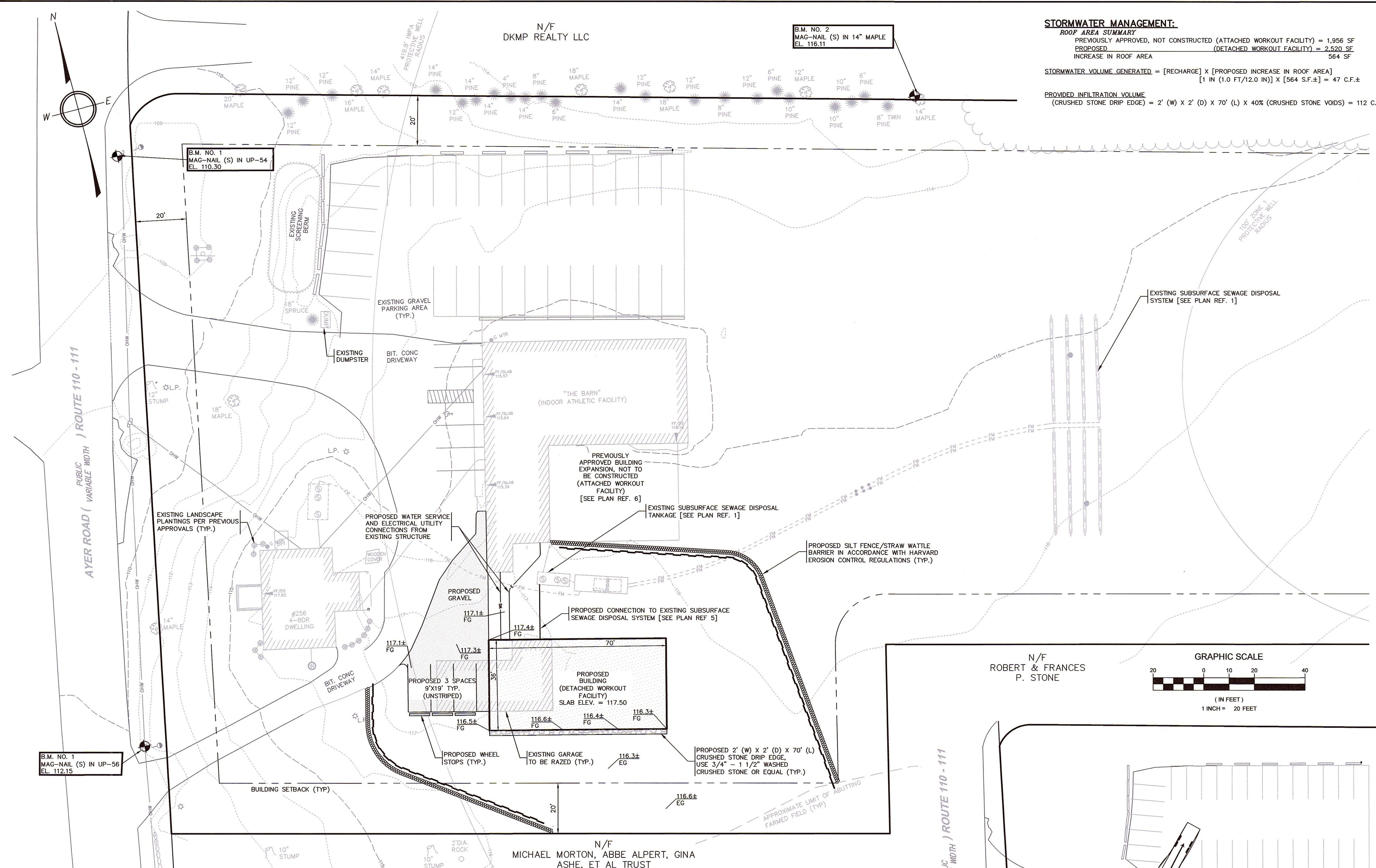

PLOT PLAN
 SCALE: 1" = 150'

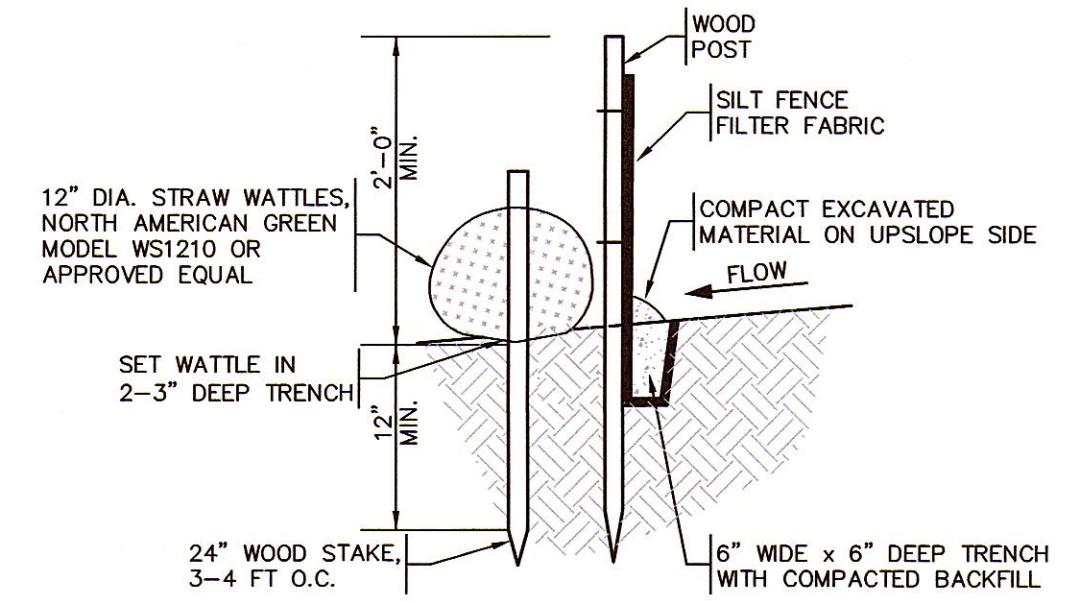

NOTES:
 [1] INSPECT AND REPAIR FENCE AFTER EACH STORM EVENT AND REMOVE SEDIMENT WHEN NECESSARY.
 [2] TRAPPED SEDIMENT SHALL BE REMOVED TO A NON-SENSITIVE UPLAND AREA.

SILT FENCE / STRAW WATTLE BARRIER
 TYPICAL CROSS SECTION
 NOT TO SCALE

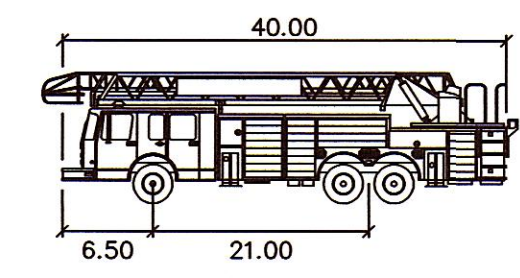

EMERGENCY VEHICLE

Width : 6.50 feet
 Track : 8.50 feet
 Lock to Lock Time : 6.00 seconds
 Steering Angle : 38.7 degrees

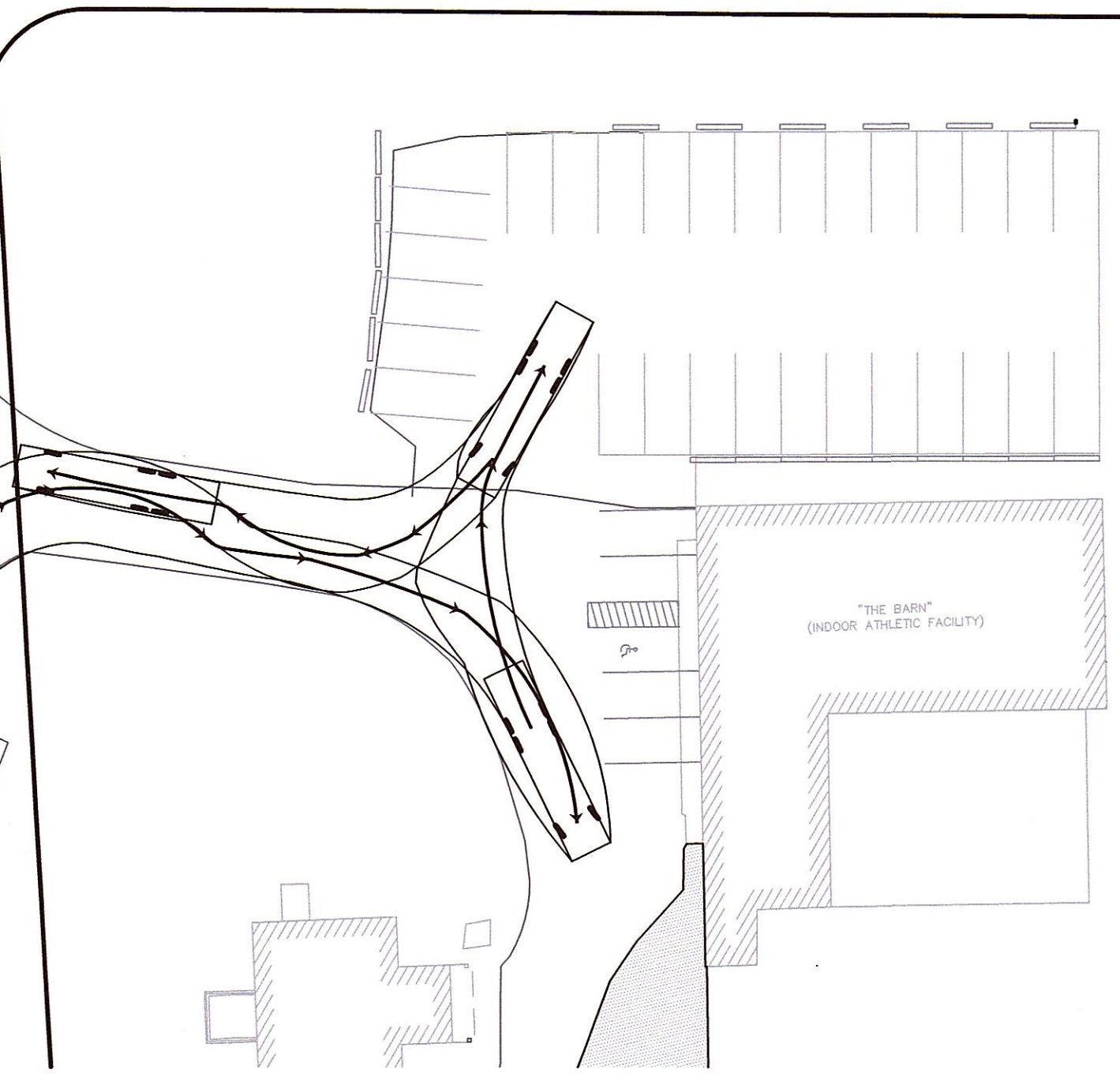

FIRETRUCK TURNING TEMPLATE
 SCALE: 1" = 30'

2024 © COPYRIGHT GOLDSMITH, PREST & RINGWALL, INC.

RE: 256 Ayer Road #2

James Garreffo <JGarreffo@nashoba.org>

Thu 4/25/2024 15:57

To: Frank O'Connor <FOConnor@harvard-ma.gov>

📎 1 attachments (269 KB)

20240425155155583.pdf;

Frank,

Our office received a plan from the applicant's engineer to connect a new building to the sewage disposal system at the abovementioned site. As part of the review of the proposed work, I review the current sewage disposal system paperwork to ensure the existing system was designed to handle the proposed additional space. When I reviewed the paperwork for this site, I noted the existing sewage disposal system was designed for existing uses: a four bedroom house and three service bays. In response to the proposed plan, I sent the applicant's engineer an email (below) asking to discuss how the sewage flow for the current use applies to the use permitted by the Board of Health; I'm not immediately concerned the sewage disposal system will be overloaded but I do not know, with any specificity, how the current building is being used (number of participants, floor plans detailing the uses in the building) and how the addition of the new building will affect the sewage flow to the existing system.

I reviewed the plan to connect a proposed new building to the existing sewage disposal system on this site. When I pulled the septic system design, I was a little confused with the calculation of the design flow (the use of garage bays).

When the applicant had applied for a building permit in the fall, I had asked for floor plans for the new building to determine if the design flow at the site would be exceeded, I have not seen the plans for the new building.

I believe we need to discuss the uses on the site and arrive at a design flow to the septic system that make sense for the current and proposed uses and I the first thing I need is the plans for the existing and proposed building uses.

I hope this helps.

Jim Garreffo, Director
Nashoba Associated Board of Health
30 Central Ave
Ayer, MA 0432

978 772 3335 X305
jgarreffo@nasahoba.org.

From: Frank O'Connor <FOConnor@harvard-ma.gov>

Sent: Thursday, April 25, 2024 8:21 AM

BROWN & BROWN, P.C.

COUNSELLORS-AT-LAW

110 GREAT ROAD

BEDFORD, MASSACHUSETTS 01730

TELEPHONE (781) 275-7267

TELECOPIER (781) 275-6940

WEBSITE: www.brown-brown-pc.com

Email: pbrown@brown-brown-pc.com

OF COUNSEL
GEORGE E. FOOTE

JOHN F. BROWN - (1891-1959)

NATHANIEL K. BROWN

MARK S. RAFFA

JAMES M. DONOVAN

PAMELA J. BROWN, FAICP

ERIC R. PRICHARD

BRITNEY M. MARTIN

* ALSO ADMITTED IN NEW HAMPSHIRE

January 21, 2024

Mr. Richard S. Cabelus, Chair
Ayer Planning Board
13 Ayer Road
Harvard, MA 01451

RECEIVED
HARVARD TOWN CLERK
2024 FEB 27 PM 3:33

RE: 288 Ayer Road – Special Permit Request for Bespoke Landscaping

Dear Mr. Cabelus and Members of the Board:

On behalf of David and Jeffrey Rossi, owners of the property at 288 Ayer Road (as Trustees of The 39 Eaton Realty Trust) and Scott Rossi, owner of Bespoke Contracting LLC, we seek the Board’s review and approval of a special permit to allow use of a portion of the property for a landscape contracting business. This use is permitted in accordance with Zoning bylaw §125-23.B(1) (Medium scale commercial uses) and 125-13.T (Landscaping services involving equipment parking).

As the property is already characterized by an existing two-family home, the resulting use mix would also support the goals of §125-13.Z (1) Mixed-use Village Development (MUVD). The applicant intends to conduct a family landscaping business to the rear of the existing dwelling. The landscaping business is a division of Bespoke Contracting’s home improvement and construction business, currently located Belmont. Harvard will serve as a satellite facility for conduct of the landscaping business, similar to the satellite in the owner’s hometown of Bedford (see photos attached). In association with the business, landscaping machinery, equipment and material stock (stone, brick, gravel, etc.) will be stored on site for use on projects in Harvard and surrounding communities. In the future, it is anticipated that a garage might be constructed to allow equipment to be stored under cover; however, no structures are proposed at this time.

The existing 8.53-acre site is located in the Commercial zoning district and characterized by a house built c. 1890 that was recently renovated by the property owner. The two-family home is vested in accordance with Harvard Zoning §125-3 and presently rented. A stream and wetland through the center of the site leaves 3.41 acres of upland (outside of the 100-foot wetland buffer) in the front portion of the property abutting Ayer Road, with another upland area upgradient of the wetland system to the east. A small portion of the easternmost section of the lot is in the Agriculture - Residential Zone, although none of the A-R zoned land is proposed for use.

Harvard's Protective Bylaw §125-23 indicates that *"The intent of the C District is to permit shopping and business services type land uses that meet the needs of the local community rather than the region, and to encourage uses that, when established, result in a traditional New England village form of development of appropriate scale, character, vernacular architecture, design, and detail."*

Bespoke will serve Harvard and beyond. In addition, the mix of uses with the residential dwelling closer to the street and commercial activity at the rear of the property is reflective of historic land use patterns. Under §125-39 Site Standards, paragraph D(2) applicable to medium-scale commercial uses, "any outdoor area for storage or for utilities shall be screened from view from neighboring properties and streets." The non-residential uses on site will be set back over 50 feet from Ayer Road. The Rossi family intends to extend the 6-foot stockade fencing to buffer the contractors' yard from the adjacent office use at 284 Ayer Road and has already installed many arborvitaes to screen the proposed use from abutting properties and Ayer Road.

The 288 Ayer Road neighborhood is mixed in terms of use. Immediately across the street at 289 Ayer Road is Harvard Outdoor Power Equipment, an adjacent shopping center including Sorrento's Pizza, a package store and real estate office located at 285 Ayer Road, and Rollstone Bank & Trust at 283 Ayer Road. Kennedy & Company, Inc. is located north at 295 Ayer Road. Bespoke does not anticipate being a direct competitor to Kennedy. The area is also characterized by a two-story multi-tenant brick office building at 280 and the adjacent building at 284 Ayer is home to a certified public accountant and financial advisor. The landscaping operations at 288 Ayer Road will be a low impact complement to the neighborhood, with limited daily activity and visibility from the street. Activity will include deliveries, loading and storage for off-site construction and landscape installations.

As no buildings are presently proposed, and existing curb cuts will be used, we respectfully request a waiver of any specific site plan details not shown on the enclosed plans. A detailed response to the provisions of §125-38 and §125-39 follow. Visually, the landscape contractor operations will be hidden from the street. We believe that the property owner and related party Bespoke Landscaping will be a good neighbor to all and trust that the Board will agree to issue a special permit for the proposed landscape contractor use.

We look forward to responding to any questions you might have at an upcoming meeting of the Planning Board.

Very truly yours,

Pamela J. Brown

COMPLIANCE WITH BYLAW STANDARDS

§125-38 Site plans.

Site plan approval is required for uses subject to § 125-39, Site standards, and as such is required for the proposed landscape contractor use. That said, no buildings are proposed and the existing curb cut will be used for access to the non-residential area of the site. Neither the access drive nor equipment/vehicle parking areas are proposed to be paved. For these reasons, we respectfully request waivers from site plan requirements where such requirements are not applicable to the proposal.

Content of Plans:

- (1) Lot boundaries and existing buildings are shown. **The site plans included show the property lines and existing structure. As no new structures are proposed, photographs of the existing two-family home at the front of the site are included.**
- (2) Parking, loading, maneuvering, storage and service areas or uses, walkways, driveways, lighting, green areas and visual screening. **Driveways and equipment storage areas are shown as well as existing and proposed fence and buffer landscaping.**
- (3) Provisions for water supply and reservoirs, surface water drainage, and treatment and disposal of sewage and any other wastes. **Not applicable to the landscape contractor yard. The existing dwelling is serviced by utilities; however, the commercial use will not require water supply or sewage disposal. Drainage shall remain as in the existing condition.**
- (4) Levels and grades where substantial excavation or fill is involved. **Not applicable, no excavation or fill is proposed.**
- (5) Clearing limits used to calculate both the volume and rate of surface water runoff. **Not applicable, no clearing is proposed and no additional impervious surface will be installed. The limit of site for the contractor's yard is shown on the plans.**

Design Review:

The requirements of 125-38 F. relate to the design of buildings – **Not applicable as no new buildings are proposed.**

§125-39 Site Standards.

A. Parking and loading.

- (1) Driveway access will be over the existing driveway located to the north of the house, parking, turnaround and storage areas will not be paved and will not be shared with adjacent lots.
- (2) The existing driveway to serve the landscape contractor's use provides convenient and safe access for vehicles. The use is not open for public visitation, so potential pedestrian conflicts are avoided.
- (3) There are no delineated parking spaces or parking access aisles. The majority of the site will be left "green" (undeveloped). Subsections (a) and (b) are not applicable.
- (4) All outdoor areas for storage or overnight parking of trucks, trailers and equipment are set back from the street and will be fenced and buffered by vegetation from the existing home, abutters and the street.
- (5) The existing curb cut at Ayer Road is sufficient to handle the turning radius of all vehicles intended to enter the site.

B. Standards for driveways.

- (1) This section of Ayer Road is straight, and therefore, driveway sight distance is easily satisfied. Using the most conservative standard with 50 mph speeds, stopping sight distance per ASSHTO is 425 feet. As shown in the exhibit attached, stopping sight distance is at least 600' to the north and 850' to the south.
- (2) – (4) Residential provisions are not applicable to Landscape contractor use.
- (5) Non-residential Driveway Standards.
 - (a) Only one site driveway is proposed for access to the landscaping operations.
 - [1] a formal traffic island is not proposed, as the single non-residential entrance/exit driveway will remain gravel, minimizing visual impact.
 - [2] trip generation will not exceed 400 ADT, rather, closer to 10 daily trips.
 - (b) The use of the property will preserve the buffer strip defined in §125-39C(1), by providing a minimum 20-foot setback between the property lines and the area of commercial activity.
 - (c) No internal roadways are proposed, the access driveway exists and the abutting uses are not similar in nature to make interconnections between adjacent properties desirable.
 - (d) The site is not being re-developed, but rather a small business will utilize the land to the rear and side of the existing 2-family home; a new curb cut is not necessary.
 - (e) The angle of intersection of the site driveway with Ayer Road is close to 90°. The entrance is slightly flared to allow turning of larger trucks or trucks with trailers. There is sufficient area within the site that to permit a truck to turn around. In an emergency, secondary access is also available through the residential driveway (which is separated from the commercial use by a gated fence).

(6) Driveway Construction.

In general, this section is not applicable. The proposed use will be very low intensity and no driveway or parking area is proposed for pavement. The use does not invite the public and no structures are proposed to support the landscape contractor's yard. The existing gravel surface is sufficient for the proposed use by Bespoke and the public will not access the area. As it is not paved, stormwater runoff will infiltrate or flow over vegetated areas toward the wetland area located over 100 feet to the east. According to the NSCS, the majority of the area proposed for the contractor's yard is Walpole, fine sandy loam. Stormwater has and will continue to infiltrate the land surface.

- (7) Turnarounds. Existing since 1890, the 2-family dwelling is served by a single driveway along the property's 277 feet of frontage. Access to the commercial area is gained from the end of this driveway via gate in the fence; however, primary access to the Bespoke yard is by the existing driveway north of the residential driveway. The area of the commercial yard is sufficient to turn around large trucks (able to satisfy the 30' inside radius requirement).
- (8) Runouts. The existing driveway width is consistent running from Ayer Road into the open yard portion of the site, excepting the limited turning area at the street. As an informal gravel driveway, there is no curbing or pavement proposed.

C. Open areas.

- (1) A buffer strip is proposed along each common property line with abutters on Ayer Road. In accordance with subsection C (1)(a), a small business identification sign is proposed at the driveway entrance to distinguish the entrance from the residential driveway. The

proposed Entrance Sign shall not to exceed 10" height by 30" length, similar to a street sign, but installed lower to the ground. Below is an image of the proposed signage.



- (2) The site is over 1,100 feet deep. All of the developed area (residential and proposed commercial) is located on the front quarter of the site, with no activity proposed beyond the point 300' distant from Ayer Road. Existing vegetation along Ayer Road will remain and additional buffer landscaping and fence will be installed.

D. Screening

- (1) As the business use of the property is anticipated only during daylight hours, and no buildings are to be constructed, no site lighting is proposed.
- (2) As shown on the Plan, all outdoor storage of equipment and materials shall be buffered from the street and abutters.
- (3) Regardless of applicable exceptions, screening is provided.
- (4) Screening includes 6' wood stockade fence coupled with arborvitae plantings.

E. Fire Protection. Not applicable, no buildings proposed.

F. Drainage. The use of the land as a landscape contractors yard will not change the stormwater runoff characteristics. We do not believe that the DEP Stormwater Management guidelines are applicable as no pavement or buildings will be added.

G. Sidewalks. Given the small scale of the proposal and the particular use, sidewalks (internal or on Ayer Road) would not benefit the business. Further, no sidewalks currently exist on this section of Ayer Road. If desirable to support a community master plan, the applicant would consider the grant of a sidewalk easement for future development by the Town.

APPLICATION TO THE HARVARD PLANNING BOARD

Applicants should review the Harvard Protective (Zoning) Bylaw, Chapter 125 of the Code of the Town of Harvard, the Planning Board's Rules and Regulations, Chapter 133 of the Code of the Town of Harvard and the Requirements regarding Driveway Inspections (Chapter 125 of the Protective Bylaw). Copies of the Bylaw may be purchased from the Town Clerk and copies of the Rules and Regulations may be purchased from the Land Use Office. Information is also available online at www.harvard.ma.us. The Rules and Regulations specify the documents that are required as a part of the application. The Application, with certified abutters list and filing fee, must be filed with the Town Clerk.

Name of Applicant: Pamela J. Brown, Esq. for Bespoke Landscaping

Address: Brown & Brown PC Phone: (781) 275-7267 Email: pbrown@brown-brown-pc.com

Applicant is (check one): Owner _____ Agent X Prospective Buyer _____

Location of Property: 288 Ayer Road Zoning District: C

Harvard Assessors' Map 004 Parcel 34

Registry of Deeds: Book Number 67617 Page Number 325

Owner's Name: Dave & Jeff Rossi, Trustees Email: david@rerfuel.com

Owner's Address: 3 Minuteman Drive, Bedford 01730 Owner's Phone: (617) 429-7234

Seventeen (17) copies of the application must be submitted to the Town Clerk. This application is for:

- | | |
|--|-------------------------------|
| <input checked="" type="checkbox"/> Special Permits* | \$500/required permit |
| <input type="checkbox"/> Driveway Site Plan | \$180 |
| <input type="checkbox"/> Inspections of Driveways | \$300 |
| <input type="checkbox"/> Approval of Covenant | \$100 |
| <input type="checkbox"/> Wireless Communication Tower | \$2500 |
| <input checked="" type="checkbox"/> Consultant Review Fee** | \$1000 |
| <input checked="" type="checkbox"/> Site Plan Review with a Special Permit | \$180 |
| <input type="checkbox"/> Site Plan Review without a Special Permit | \$500 |
| <input type="checkbox"/> Modification/Extension | ½ of original application fee |

Specific bylaw section(s) you are applying under §125-23 B(1) (Medium scale commercial uses) and 125-13.T
 (Landscaping services involving equipment parking).

* Unless otherwise specified

** Required with all Special Permit Applications. This is a deposit to cover costs of Planning Board consultants and additional amounts may be required depending on the complexity of the Application. All unused monies will be returned. Please submit "Request for New Vendor" form with application. (Available on line at www.harvard.ma.us under Forms & Documents)

All applications associated with a Wireless Communication Tower requires proof of compliance with § 125-27H(2)

All filing fees are cumulative. All Special Permits and uses subject to Site Plan Approval require Driveway Inspections and written approval by the Planning Board, or its agent, prior to issuance of an occupancy permit or use of the premises (§ 125-31 C) All Shared (common) Driveways require an approved covenant running with the land in accordance with § 125-31 B (4) (b). The applicant will be required to pay a local newspaper of general circulation for the current cost of advertising the hearing. The applicant will be billed directly from the newspaper for the cost of the advertised hearing or all advertising must be paid for in full prior to submittal to the newspaper. The undersigned hereby requests a hearing before the Planning Board with reference to this application.

Signed: 

Revised November 7, 2016

2024 FEB 27 PM 3: 31

RECEIVED
HARVARD TOWN CLERK



July 5, 2022

288 Ayer Road

Harvard, MA

1 inch = 2221 Feet



www.cai-tech.com

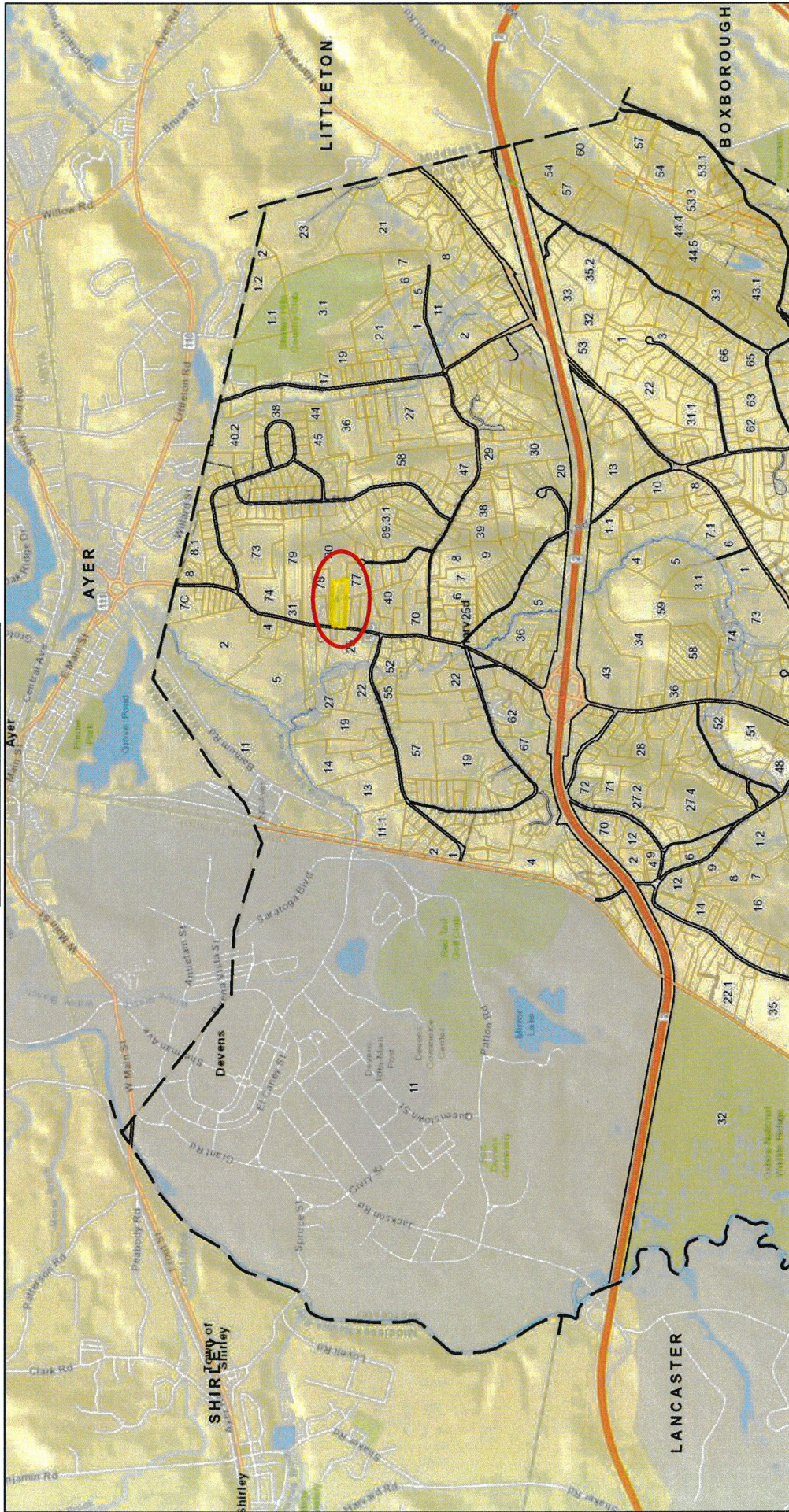

Data shown on this map is provided for planning and informational purposes only. The municipality and CAI Technologies are not responsible for any use for other purposes or misuse or misrepresentation of this map.

AYER ROAD



Existing
2-family home

AREA
(OUTSIDE WETLAND BUFFER)
3.15± ACRES

Proposed Bespoke
Landscaping Yard

100' BUFFER WETLAND

WETLAND LIMIT

LOT 2
8.53± ACRES

WATER LINE

WETLAND LIMIT

Wetland

100' BUFFER WETLAND

NOTE:
WETLAND AND WATER LINE FROM
TOWN OF HARVARD GIS, 7/21/2020

PREPARED FOR: DAVID ROSSI

CERTIFIED PLOT PLAN
#288 AYER ROAD
IN
HARVARD, MA
(MIDDLESEX COUNTY)

SCALE: 1" = 120' DATE: 7/22/2020



ROBER SURVEY
1072A MASSACHUSETTS AVENUE
ARLINGTON, MA 02476
(781) 648-5533
6144 AYER.DWG

CLIFFORD E. ROBER, PLS DATE
THIS PLAN MAY HAVE BEEN ALTERED IF
THE SIGNATURE IS NOT SIGNED IN BLUE.

AYER ROAD

104=11

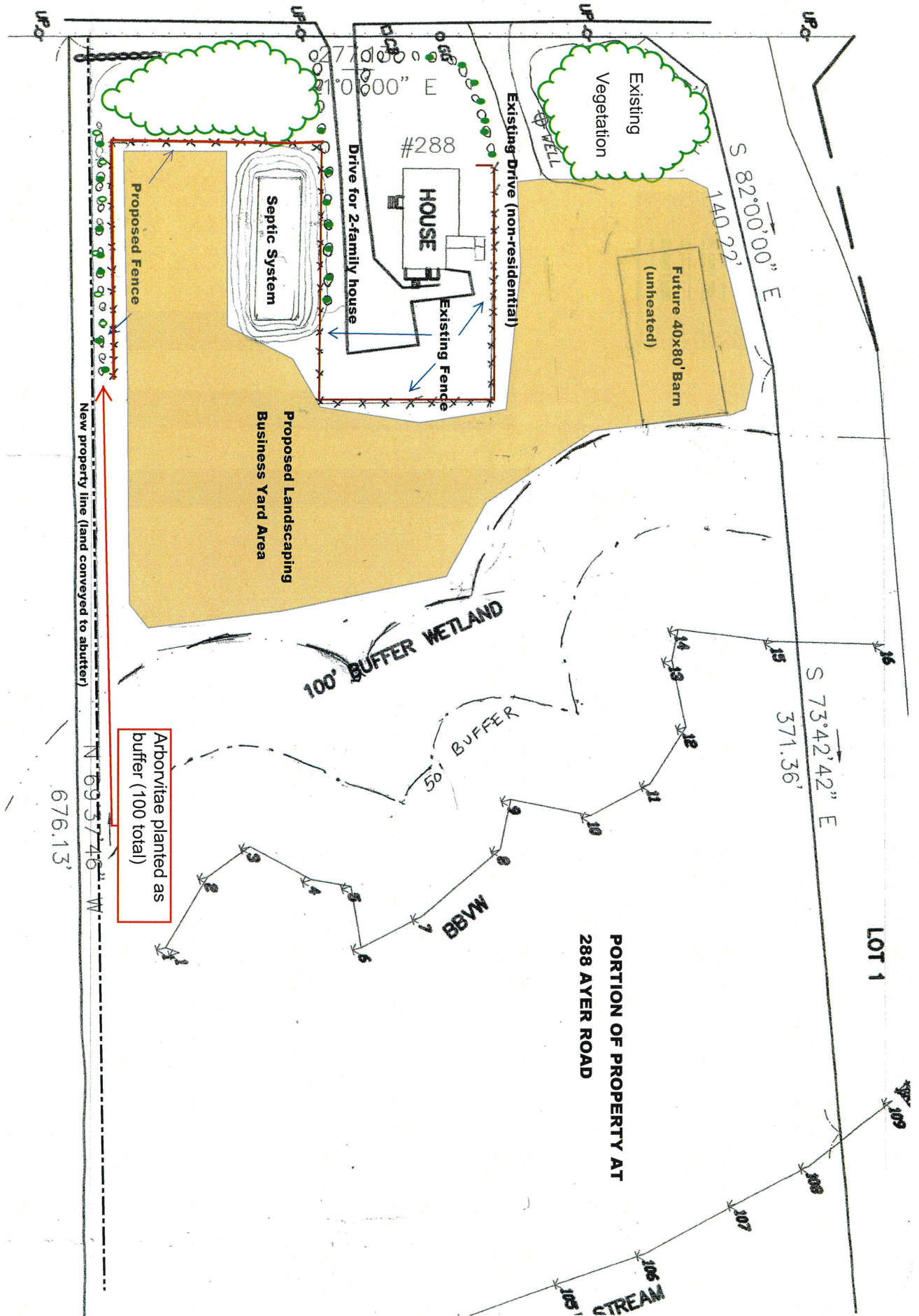

Arborvitae planted as buffer (100 total)

PORTION OF PROPERTY AT 288 AYER ROAD

LOT 1

STREAM

100' BUFFER WETLAND

50' BUFFER

BBVW

Proposed Fence

Proposed Landscaping Business Yard Area

Drive for 2-family house

Existing Drive (non-residential)

#288

HOUSE

Future 40x80' Barn (unheated)

Septic System

Existing Vegetation

WELL

S 82°00'00" E 140.29'

S 73°42'42" E 371.36'

676.13'

N 69°57'46" W

New property line (land conveyed to abutter)

0.000" E

109

108

107

106

105

16

15

14

13

12

11

10

9

8

7

6

5

4

3

2

1

CONSERVATION PLAN

IN
HARVARD, MA
(WORCESTER COUNTY)

SCALE: 1" = 60' DATE: OCTOBER 20, 2020

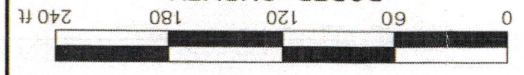

ROBER SURVEY
1072A MASSACHUSETTS AVENUE
ARLINGTON, MA 02476
(781) 648-5533
62961P2.DWG

NOTE: WETLAND BOUNDARY LINE DELINEATED BY ECOTEC, INC., OCTOBER 2020.
LANDSCAPE BUSINESS AREA ADDED 8/7/23

WITHIN 100' BUFFER
TOTAL BUFFER AREA 44,091± S.F.
EXISTING IMPERVIOUS AREA 0± S.F. 0%
PROPOSED IMPERVIOUS AREA 0± S.F. 0%
SEE LANDSCAPE PLAN FOR DETAILS

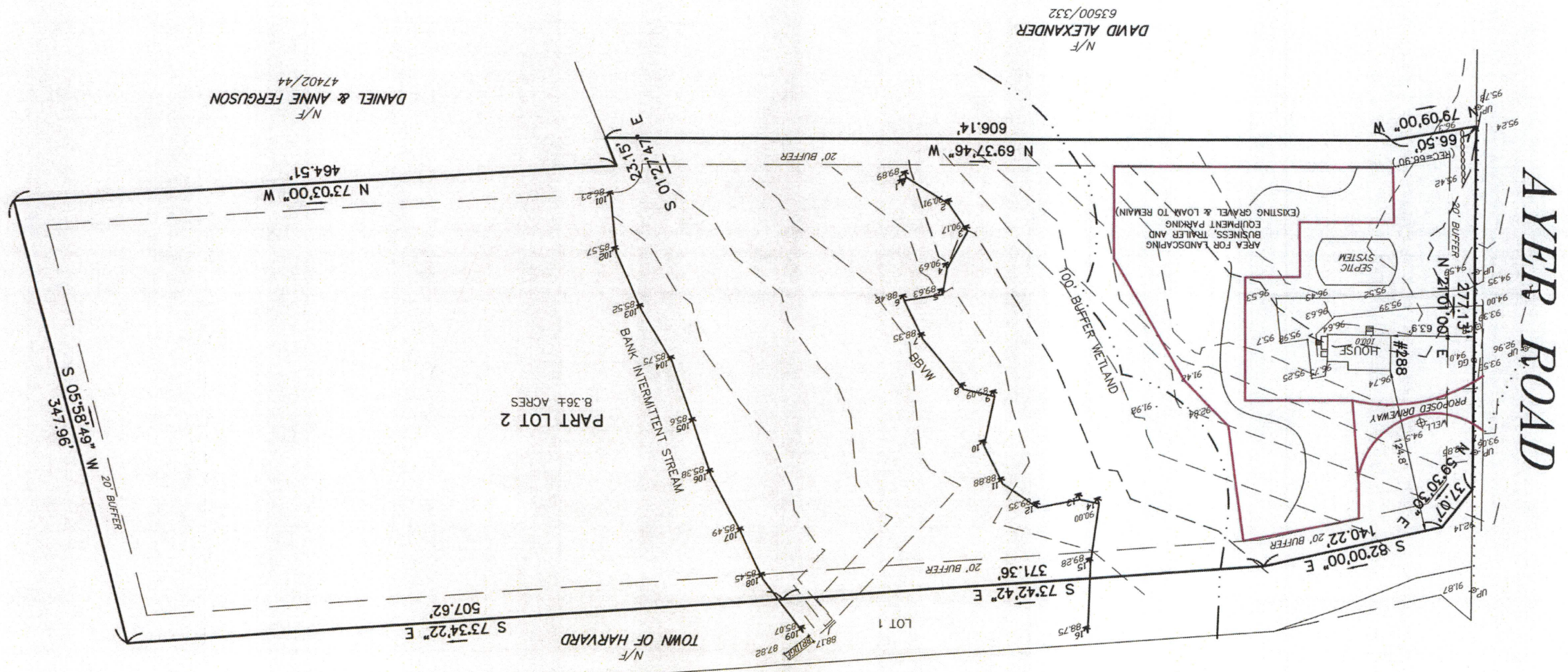

Photos of 288 Ayer Road, viewed from front of 289 Ayer Road



View near property line with 294 Ayer Road (above)



Two-family home centered at 288 Ayer Road frontage (new fence and buffer arborvitae installed 2022)



Looking south across 288 frontage toward property at 284 Ayer Road



Aerial photo of site showing approximate area for landscaping business use. (above)



Landscape contractor nearby on Ayer Road

AYER ROAD

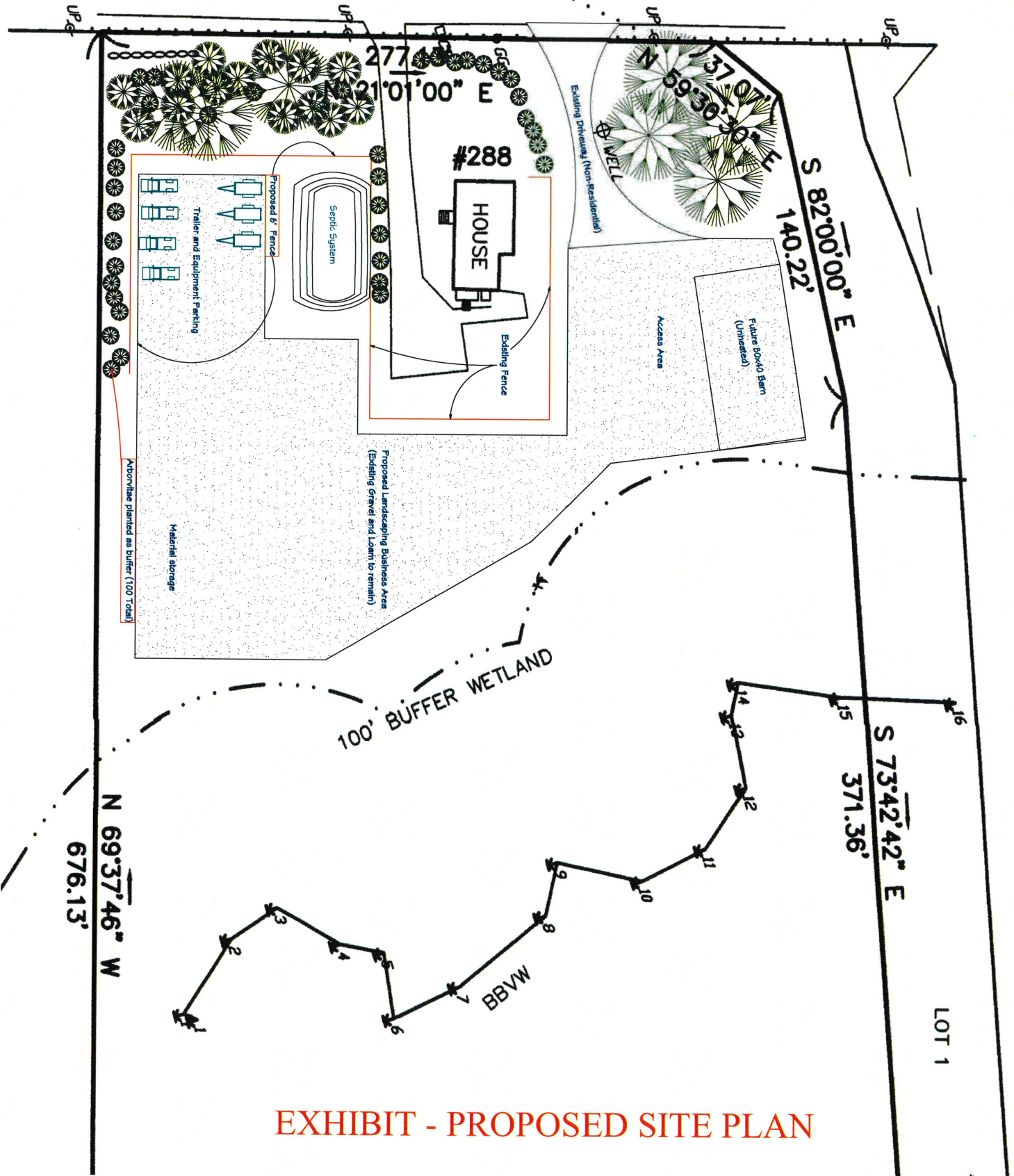
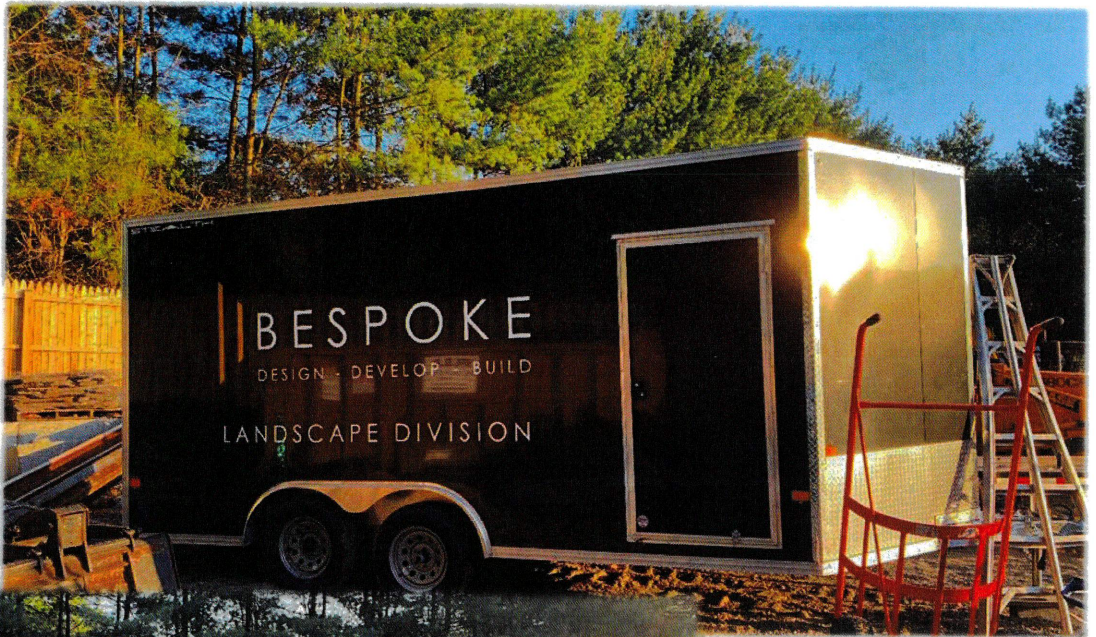
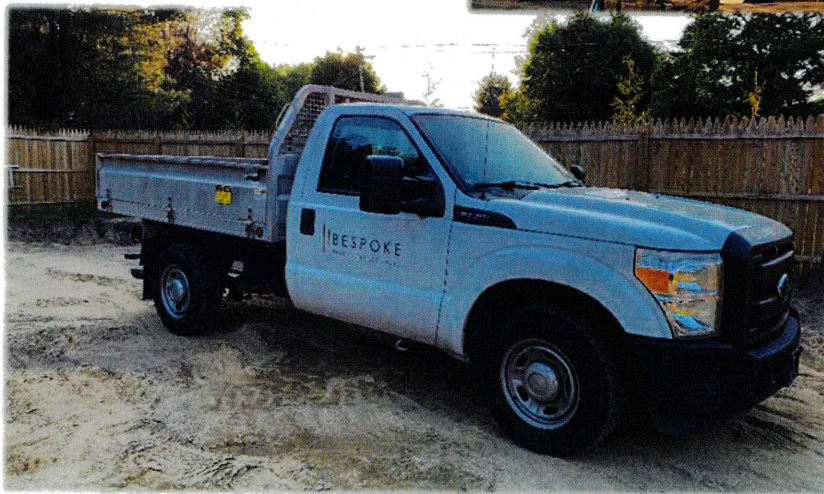

EXHIBIT - PROPOSED SITE PLAN



BESPOKE Landscaping – vehicles and equipment presently in Bedford, representative of equipment proposed for Harvard.





288 Ayer Road, Harvard – Stockade fence surrounds residential yard. Significant areas of upland and wetland buffer remain to the east.





288 Ayer Road, Harvard – Stockade fence and arborvitae will buffer activity from neighbors.



**Bedford,
similar fence/buffer proposed for Harvard**

REQUEST FOR NEW VENDOR

REQUESTOR'S NAME David Rossi, Trustee, The 39 Eaton Realty Trust

DATE _____

PHONE (617) 429-7234

Please check the box which best describes the type of vendor.

1099 Code

EMPLOYEE (reimbursements)

PRODUCT VENDOR

SERVICE VENDOR

CONTRACT LABOR

7 *If using SS number*

7

VENDOR NAME _____

ADDRESS _____

CITY, STATE, ZIP _____

PHONE _____

FAX _____

FID NUMBER _____

OR (Without the proper FID or SS number vendor can not be paid!)

SOCIAL SECURITY NUMBER _____

(Without the proper FID or SS number vendor can not be paid!)

REMIT ADDRESS _____

If different

CITY, STATE, ZIP _____

Do not write below this line

VENDOR NUMBER _____

DATE SET UP _____



2/27/2024

To whom it may concern,

This letter is intended to better describe the intention of the commercial use for the property at 288 Ayer Rd. We have no plans to use this as a daily headquarters for our operation. We are simply asking to use the commercial land for monthly storage of materials and equipment when not in use. This would be an overflow location to our existing location in Bedford MA. For an example of the type of materials and equipment which could be stored from time to time please see the list below:

- 1) Enclosed equipment trailers.
- 2) Landscape and open equipment trailers.
- 3) Jobsite storage containers.
- 4) Plows, truck attachments etc.
- 5) Backhoe loader.
- 6) Mini-excavator and skid steer loaders.
- 7) Genie Man-lift.
- 8) Knuckle-boom crane swap n' go box.
- 9) Dump truck.
- 10) Equipment trucks.
- 11) Chip body attachments for trucks.
- 12) Swap n' go loader truck and body attachments.
- 13) Palleted materials such as stepping stones, brick, cinderblocks etc.
- 14) Aggregates, such as sand and crushed stone could be stockpiled from time to time, but we have no intention of daily loading or short term storage of these materials, so set retaining block walls for mulch etc. is not planned. Materials would only be placed and left for long (months) periods of time, and not loaded in and out regularly.

While this list is not exhaustive of all possible materials, it is complete in the spirit of materials and equipment that we own and use. This list is also not intended to mean that these materials will all be onsite at any given time as our inventory is often in flux, and equipment is mostly at open projects.

This would not be a daily operation, and hours of use would be typical to business operations (8-4). There would not be any customers at this location, and mostly storage would be long term through the off season.

Thank you for your time and consideration of our application,

A handwritten signature in black ink, appearing to read "Scott Rossi".

Scott Rossi,
Founder
Bespoke Companies